

EN

# Semi-automatic rifle Match Rifle MR308 A3

**.308 Win. Calibre**

**MR308 A3 16,5"**

**MR308 A3 20"**

**MR308 A3 28**



## Operator's Manual

**HK**

# Semi-automatic rifle Match Rifle MR308 A3

**.308 Win. Calibre**

**MR308 A3 16,5"**

**MR308 A3 20"**

**MR308 A3 28**

** DANGER**

**Risk of death from gunshot wounds!**

**Accidental discharge of weapon may occur when loaded weapon is handled.**

- › Do not use the weapon until you have read and understood this manual completely.
- › Follow the safety instructions when handling the weapon.
- › Carry out a safety check before working on the weapon.





## Functional elements - left side view



The illustrations on the front and back fold-out pages show the functional elements of the weapon from the left and right sides. The text refers frequently to these illustrations. Opening the fold-out pages while reading will make it easier to understand the text.



Fig. 1a: Match Rifle MR308 A3, left side view

- |   |                                  |    |                            |
|---|----------------------------------|----|----------------------------|
| 1 | Barrel                           | 8  | Safety lever, ambidextrous |
| 2 | Front sight, folding             | 9  | Trigger                    |
| 3 | Handguard with Picatinny rails   | 10 | Magazine, 10 cartridges    |
| 4 | Bolt catch/release, ambidextrous | 11 | Flash hider                |
| 5 | Rear sight                       | 12 | Follower                   |
| 6 | Charging handle                  | 13 | Magazine lips              |
| 7 | Buttstock cap                    |    |                            |

## Functional elements - right side view



The illustrations on the front and back fold-out pages show the functional elements of the weapon from the left and right sides. The text refers frequently to these illustrations. Opening the fold-out pages while reading will make it easier to understand the text.

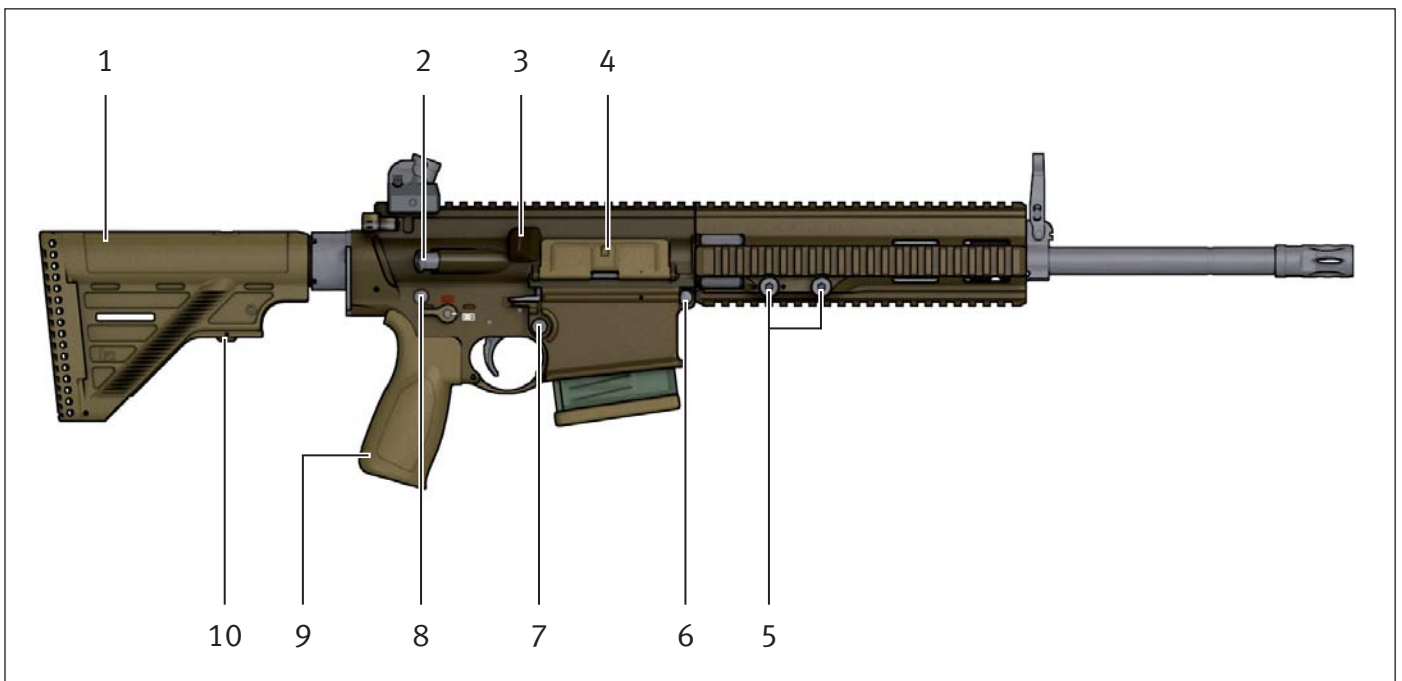

Fig. IIa: Match Rifle MR308 A3, right side view

- |   |                              |    |                              |
|---|------------------------------|----|------------------------------|
| 1 | Buttstock, adjustable        | 6  | Locking pin, front           |
| 2 | Forward assist               | 7  | Magazine catch, ambidextrous |
| 3 | Cartridge case deflector     | 8  | Locking pin, rear            |
| 4 | Ejection port cover          | 9  | Pistol grip                  |
| 5 | Locking screws for handguard | 10 | Buttstock release lever      |



## Table of contents

### Part I Description

<b>1</b>	<b>Using this manual</b> .....	<b>3</b>
1.1	Purpose of this manual .....	3
1.2	Target audience for this manual .....	3
1.3	Warnings, notes and information .....	3
<b>2</b>	<b>Fundamental safety instructions</b> .....	<b>7</b>
2.1	The operator's manual as an integral component of the safety concept ...	7
2.2	Safety instructions for handling the weapon .....	7
2.3	Safety instructions for firing .....	10
2.4	Exclusion of liability and warranty .....	10
<b>3</b>	<b>Description of the weapon</b> .....	<b>11</b>
3.1	Designation .....	11
3.2	Intended use .....	11
3.3	Scope of supply .....	11
3.4	Overview of variants .....	12
3.5	Assembly groups .....	15
<b>4</b>	<b>Technical description</b> .....	<b>16</b>
4.1	Safety features .....	16
4.2	Functional elements .....	17
<b>5</b>	<b>Cleaning kit and auxiliary materials</b> .....	<b>18</b>
5.1	Minimum cleaning kit .....	18
5.2	Maximum cleaning kit .....	19
5.3	Auxiliary materials .....	21

## Part II Handling

<b>6</b>	<b>Checks</b> .....	<b>25</b>
6.1	Carrying out a safety check .....	25
6.2	Carrying out a function check .....	26
<b>7</b>	<b>Preparations</b> .....	<b>28</b>
7.1	Adjusting the buttstock .....	28
7.2	Adjusting the buttstock MR308 A3 28 .....	29
7.3	Adjusting the sights .....	33
7.4	Filling the magazine .....	37
7.5	Preparing the weapon for firing .....	38
7.6	Additional preparations in unusual climatic conditions .....	40
<b>8</b>	<b>Operation</b> .....	<b>41</b>
8.1	Inserting the magazine .....	41
8.2	Chambering a round .....	41
8.3	Firing position and aiming .....	42
8.4	Firing .....	45
8.5	Removing the magazine .....	46
8.6	Reloading the weapon .....	47
8.7	Unloading the weapon .....	47
8.8	Empty the magazine .....	48
<b>9</b>	<b>Cleaning</b> .....	<b>49</b>
9.1	General instructions for cleaning .....	49
9.2	Disassembling the weapon .....	49
9.3	Cleaning the weapon .....	54
9.4	Assembling the weapon .....	61



---

<b>10</b>	<b>Faults: Causes and remedies</b> .....	<b>66</b>
<b>11</b>	<b>Protection, packaging and storage</b> .....	<b>70</b>
11.1	Protecting the weapon .....	70
11.2	Packaging the weapon .....	71
11.3	Storing the weapon .....	71
<b>12</b>	<b>Transport and shipping</b> .....	<b>72</b>
12.1	Preparing the weapon for transport .....	72
12.2	Transporting the weapon .....	72
12.3	Shipping the weapon .....	72
<b>13</b>	<b>Destruction and disposal</b> .....	<b>73</b>
13.1	Destroying the weapon .....	73
13.2	Disposing of the weapon .....	73



**Part I**

**Description**



## **1 Using this manual**

### **1.1 Purpose of this manual**

The first part of this manual (“Description”) describes the design and function of the weapon, and the second part (“Handling”) describes the handling of the weapon.

### **1.2 Target audience for this manual**

This manual is intended for persons who are authorised to use this weapon. This manual does not assume extensive technical or weapons-specific knowledge.

### **1.3 Warnings, notes and information**



To ensure the greatest possible safety during handling, important information and technical notes are specially highlighted.

### 1.3.1 Warnings and warning levels



Warnings are depicted as follows (example):

 <b>DANGER</b>
<p><b>Risk of death from gunshot wounds!</b></p> <p><b>Accidental discharge of weapon may occur when loaded weapon is handled.</b></p> <ul style="list-style-type: none"> <li>› Do not use the weapon until you have read and understood this manual completely.</li> <li>› Follow the safety instructions when handling the weapon.</li> <li>› Carry out a safety check before working on the weapon.</li> </ul>

The following colours and signal words are used in the warnings to indicate various warning levels:

Colour / signal word	Meaning
 <b>DANGER</b>	<p>Direct, imminent danger!</p> <p>Non-compliance will lead to death or extremely serious injury.</p>
 <b>WARNING</b>	<p>Possible imminent danger!</p> <p>Non-compliance could lead to death or serious injury.</p>
 <b>CAUTION</b>	<p>Dangerous situation!</p> <p>Non-compliance could lead to minor injuries.</p>
<b>NOTICE</b>	<p>Non-compliance could lead to material damage.</p>

### 1.3.2 Symbols used

Symbol	Meaning
	Additional information on the weapon, practical handling of the weapon or using this manual.
1.	Call to perform an action in a sequence of actions: Here you have to do something!
	Stand-alone step or call to perform an action in a warning: Here you have to do something!
»	The sequence of actions is not complete, and is continued on the next page: Please turn the page!
•	Bullet point

### 1.3.3 Conventions for illustrations



Illustrations and drawings can vary from your weapon, depending on the model.

The information “right”, “left”, “front” and “rear” apply to the position of the weapon as seen in the direction of fire.

Illustrations and their constituent elements support the descriptions in this manual, and are identified as follows:

- The name of an illustration comprises the current page number and a consecutive lower-case letter starting again from “a” on each page, e.g. 6a.
- Calls to perform an action are indicated by upper-case letters enclosed in circles.
- Components relevant to the action are highlighted in blue. Where necessary the components are marked with numbers and identified in a legend.
- Motions are indicated by orange-coloured arrows.



Abb. 6a: Example for an illustration

- 1 Charging handle
- 2 Bolt catch/release

### 1.3.4 Conventions for cross references

Cross references represent relationships between the text and an illustration or specific section. Cross references are *in italics* and enclosed in (brackets).

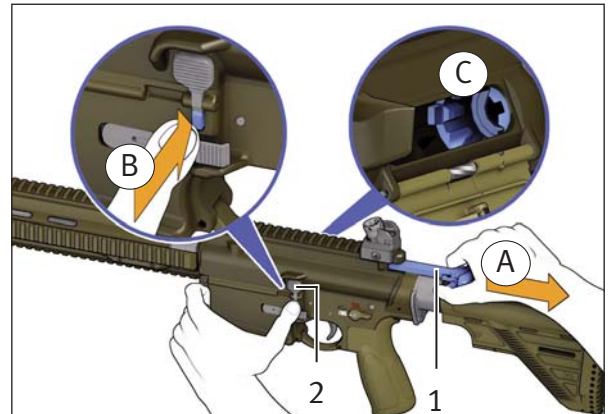
- Example of a cross reference between text and illustration: (6a-2)

The cross reference refers to numeral 2 in the illustration numbered 6a on page 6, the bolt catch/release.



The text frequently refers to the front and back fold-out pages, which are identified by the Roman numerals I (front) and II (back).

- Example of a cross reference between sections: (Section 1.3.3)

The cross reference refers to Section 1.3.3, conventions for illustrations.



## 2 Fundamental safety instructions



---

The weapon has been designed and manufactured according to the latest technical knowledge and the recognised safety rules. Nevertheless, use of the weapon may result in injury or death of the user and third parties, or damage to the weapon and other material property.

---

- › Follow all of the instructions in this operator's manual. Non-compliance may result in injury or death.
- › Do not handle the weapon if you are tired, feel unwell, or have consumed alcohol, drugs or medicines.
- › Follow the applicable regulations for the handling of weapons.

### 2.1 The operator's manual as an integral component of the safety concept



---

The operator's manual is an integral component of the weapon.

---

- › Do not use the weapon until you have read and understood this operator's manual completely.
- › Keep the operator's manual for the entire service life of the weapon.
- › If you receive any supplements or amendments, be sure to add them to the operator's manual.
- › Pass the operator's manual on to any subsequent operator or owner.
- › Do not entrust the weapon to anyone who has not read and understood this operator's manual completely.

### 2.2 Safety instructions for handling the weapon

- › Special care must be taken when handling firearms, because the position and direction of the weapon can be changed very easily.
- › Use the weapon only if it is in perfect technical condition.



- › Treat the weapon as if there were a round in the chamber and the safety released until you have carried out a safety check.
- › Make sure that the weapon is always unloaded when it is handled for purposes other than loading or firing.
- › Use the weapon only for its intended purpose. Do not use the weapon as a club, hammer, pry bar, etc. Using the weapon for other than its intended purpose may result in accidental discharge of weapon or damage to the weapon.
- › Do not play with the weapon.
- › Never point the weapon at people when handling or practising with it.
- › Do not touch the trigger when loading, unloading, aiming or handling the weapon in any other way. Always place your trigger finger on the outside of the trigger guard.
- › Do not use excessive force when handling, disassembling, cleaning and assembling the weapon.
- › Avoid dry firing of the hammer. Dry firing of the hammer can lead to premature wear.
- › Store weapon and ammunition separately. Be sure to prevent access to the weapon and ammunition by unauthorised persons, especially children.
- › Never give or take the weapon unless it is unloaded and the bolt group is in the open position.

- › Do not entrust the weapon to anyone who is not entitled to possess the weapon. Observe applicable regulations.
- › Immediately rectify any faults that compromise safety.
- › Exposure to exceptional stresses such as when the weapon is banged or dropped can have a negative effect on safety. After excessive stresses, have the weapon inspected by the manufacturer or trained firearms personnel.
- › Do not rely on safety features. Safety features are no substitute for careful, correct handling of the weapon.
- › When using accessories and ammunition, follow the instructions provided by their respective manufacturers.
- › The weapon has been designed for a specific calibre. Use only ammunition that meets C.I.P. (Commission Internationale Permanente) specifications and corresponds to the calibre of the weapon. The correct designation of the ammunition suitable for the weapon is indicated on the weapon. Especially when using reloaded ammunition, make sure that the gas pressure does not exceed the level permitted according to the standard. Excessive gas pressure can damage the weapon or cause it to explode. Ammunition whose muzzle velocity and gas pressure are higher than the muzzle velocity and gas pressure for which the weapon was designed subject the weapon to additional stresses, cause excessive wear, and can lead to serious damage to the weapon.

## 2.3 Safety instructions for firing

- › Wear hearing protection when firing.
- › Wear safety goggles when firing.
- › Keep your hands out of the path of the bolt group when firing.
- › Keep the muzzle area clear when firing.
- › Do not shoot at doors, panes of glass, walls, concrete, stone, or smooth surfaces (including water). A bullet can penetrate these objects or be deflected in an unsafe direction.
- › Pull the trigger only if the weapon is pointing at the target and the area behind the target is not endangered.
- › Use only properly loaded, undamaged cartridges of the correct calibre.
- › Wear protective gloves when touching the barrel and flash hider after firing. The barrel and flash hider heat up during firing.

## 2.4 Exclusion of liability and warranty

Heckler & Koch GmbH accepts no liability and provides no warranty for incidents arising from:

- non-compliance with this manual,
- incorrect handling of the weapon,
- negligence,
- improper use,
- modifications, attachments to or conversion of the weapon without the express written consent of Heckler & Koch GmbH, or
- use of accessories or spare parts from other manufacturers without the express written consent of Heckler & Koch GmbH.

### 3 Description of the weapon

The MR308 A3 semi-automatic rifle (.308 Win. calibre) is a semi-automatic gas-operated weapon with a rotating bolt head. The magazine (*Ia-10*) is available in two sizes, with a capacity 10 or 20 cartridges.

#### 3.1 Designation

Match Rifle MR308 A3

#### 3.2 Intended use

The Match Rifle MR308 A3 semi-automatic rifle is a firearm for sport shooting at a range of:

- 400 m with iron sight,
- 800 m with optical sight.

#### 3.3 Scope of supply



Fig. 11a: Match Rifle MR308 A3 16,5", .308 Win. Calibre

- 1 Match Rifle MR308 A3  
2 Magazine

- 3 Operator's Manual

### 3.4 Overview of variants

#### 3.4.1 Match Rifle MR308 A3 16.5"

Color: black

Barrel length 421 mm



Fig. 12a: Match Rifle MR308 A3 16.5"

#### 3.4.2 Match Rifle MR308 A3 20"

Color: black

Barrel length 508 mm, extended buttstock



Fig. 12b: Match Rifle MR308 A3 20"

### 3.4.3 Match Rifle MR308 A3 20"

Color: RAL8000 - green brown

Barrel length 508 mm, extended buttstock



Fig. 13a: Match Rifle MR308 A3 20"

### 3.4.4 Match Rifle MR308 A3 28

Color: RAL8000 - green brown

Barrel length 421 mm



Fig. 13b: Match Rifle MR308 A3 28

### 3.4.5 Match Rifle MR308 A3 28

Color: black

Barrel length 421 mm



*Fig. 14a: Match Rifle MR308 A3 28*



### 3.5 Assembly groups



Fig. 15a: Assembly groups

1 Charging handle

2 Lower receiver

3 Magazine

4 Handguard

5 Bolt group

6 Upper receiver with add-on parts

## 4 Technical description

### 4.1 Safety features

#### 4.1.1 Safety lever



The safety lever (*la-8*) can always be clicked to the “Safe” position.

The safety lever prevents accidental actuation of the trigger (*la-9*). In the “Safe” position the safety roller blocks the trigger. Only when the safety lever is clicked to the “Single fire” will the safety roller release the trigger.

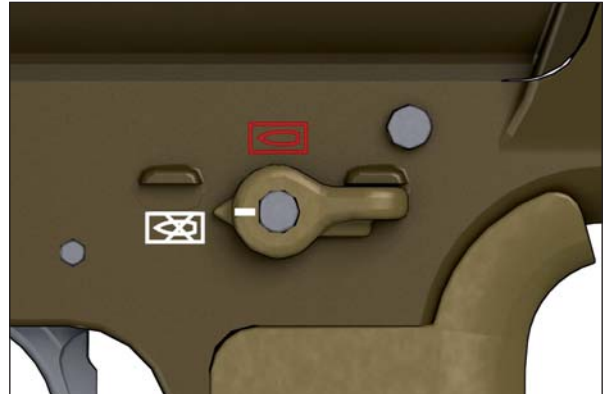

Fig. 16a: “Safe” position

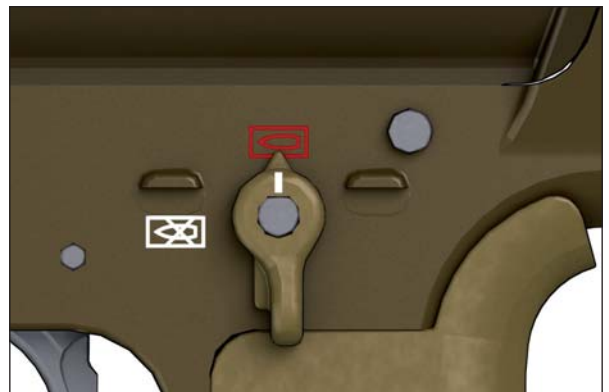

Fig. 16b: “Single fire” position

#### 4.1.2 Firing pin safety

The firing pin safety prevents accidental operation of the firing pin, for example if the weapon is dropped. The firing pin safety blocks the firing pin and prevents the firing pin from striking the cartridge primer. Only when the trigger (*la-9*) is pulled does the hammer release the firing pin safety, just before the hammer strikes the firing pin.

## 4.2 Functional elements

The safety lever (*Ia-8*) is used to make the weapon safe and to select the mode of fire.

The ambidextrous magazine catch (*Ila-7*) enables quick changing of magazines by both right-handed and left-handed shooters.

The ambidextrous bolt catch/release (*Ia-4*) serves to hold the bolt group in the open position and allow reloading when the magazine (*Ia-10*) is fired empty.

The handguard (*Ia-3*) is fastened to the barrel nut with two locking screws (*Ila-5*). The handguard is not attached to the barrel (*Ia-1*), this helps ensure the accuracy of the weapon. The handguard is equipped with Picatinny rails at the 3, 6, 9 and 12 o'clock positions.

The Picatinny rails can be used to attach various iron and optical sights and other accessories.

The adjustable buttstock (*Ila-1*) can be locked in five positions over an adjustment travel of 80 mm.

The adjustable buttstock of the MR308 A3 28 can be locked in four positions over an adjustment travel of 67 mm.

The charging handle (*Ia-6*) can be used to open the bolt group in order to chamber a round or to unload the weapon.

The forward assist (*Ila-2*) can be used to lock the bolt group manually in case of fouling.

The pistol grip (*Ila-9*) is available in various models with different ergonomics and with an integrated storage compartment.

The ejection port cover (*Ila-4*) prevents foreign bodies from entering the chamber and the path of the bolt group. Movement of the bolt group automatically opens the ejection port cover to allow cartridge case ejection.

## 5 Cleaning kit and auxiliary materials

### 5.1 Minimum cleaning kit



The cleaning kit is not included in the standard scope of supply for the weapon. The cleaning kit can be ordered from Heckler & Koch using the Ident.-No. shown.

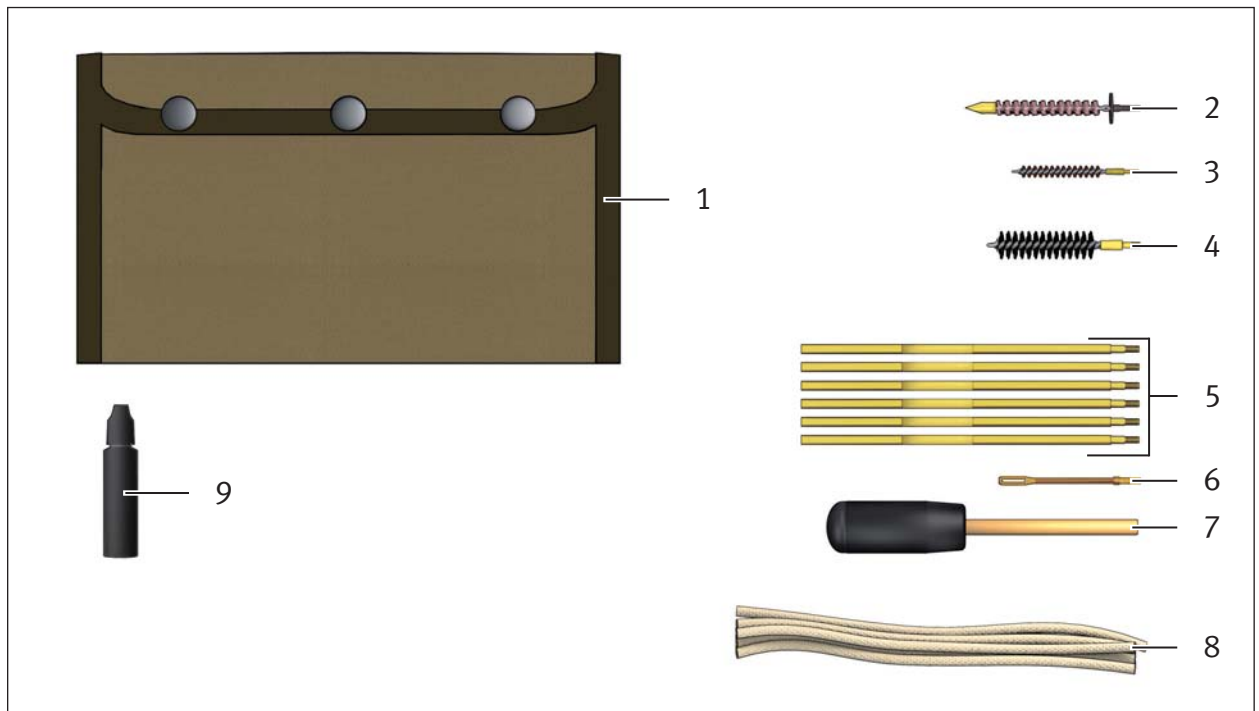

Fig. 18a: Minimum cleaning kit

Item	Minimum cleaning kit	Quantity	Ident.-No.
—	Minimum cleaning kit (Items 1 - 9)	—	236 382
1	Case for cleaning kit	1	975 245
2	Chamber cleaning brush	1	973 483
3	Barrel cleaning brush	1	978 555
4	Oil brush	1	299 176
5	Extension rods	6	973 487
6	Pull-through holder	1	973 484
7	Handle, rotatable	1	973 486
8	Cleaning pull-through, 6-strand	10	974 225
9	Oil bottle, filled	1	260 399

## 5.2 Maximum cleaning kit



The cleaning kit is not included in the standard scope of supply for the weapon. The cleaning kit can be ordered from Heckler & Koch using the Ident.-No. shown.



Fig. 19a: Maximum cleaning kit

Item	Maximum cleaning kit	Quantity	Ident.-No.
—	<i>Maximum cleaning kit (Items 1 - 20)</i>	—	237 447
1	<i>Case for cleaning kit</i>	1	975 517
2	<i>Cleaning brush for extension, bronze</i>	1	974 459
3	<i>Oil brush for extension</i>	1	974 458
4	<i>Chamber cleaning brush</i>	1	973 483
5	<i>Barrel cleaning brush</i>	1	978 555
6	<i>Oil brush</i>	1	299 176
7	<i>Cleaning brush for chamber and barrel extension</i>	1	978 549
8	<i>Extension rods</i>	6	973 487
9	<i>Pull-through holder</i>	1	973 484
10	<i>Handle, rotatable</i>	1	973 486
11	<i>Cleaning brush, brass</i>	1	979 769
12	<i>Cleaning brush</i>	1	974 187
13	<i>Cleaning rod guide</i>	1	236 618
14	<i>Cleaning pull-through, 12-strand</i>	10	974 225
15	<i>Brush, natural hair</i>	1	979 766
16	<i>Brush, plastic</i>	1	975 243
17	<i>Cleaning hose</i>	1	979 926
18	<i>T-handle</i>	1	354 759
19	<i>Oil bottle, filled</i>	1	260 399
20	<i>Cleaning cloth</i>	1	974 113

## 5.3 Auxiliary materials



---

Auxiliary materials are available from specialist dealers.

Required auxiliary materials are listed at the beginning of each section.

---

The following auxiliary materials are required in this manual:

- Grease
- 3 mm Allen key (Ident.-No. 957 428)
- 4 mm Allen key (Ident.-No. 957 429)
- 5 mm Allen key (Ident.-No. 957 430)
- Low-temperature oil (MIL-L-14107), e.g. O-157
- Oil (MIL-L-63460), e.g. Breakfree
- Oil paper
- Cleaning pull-throughs
- Screwdriver and elevation adjustment tool (Ident.-No. 300 009)





**Part II**

**Handling**



## 6 Checks

### 6.1 Carrying out a safety check



Successful completion of a safety check verifies that there is no ammunition in the weapon. The safety check is especially important when giving or taking a weapon and when you are unsure whether or not a weapon is loaded.

1. Remove magazine (*Section 8.5*).
2. Pull charging handle all the way back and hold it (*25a-A*).
3. Push bolt catch/release and hold it (*25a-B*).

#### **⚠ CAUTION**

**Risk of injury when the bolt group snaps forwards!**

**The bolt group snaps forwards when the bolt catch/release is pushed.**

› Do not reach into the path of the bolt group.

4. Push charging handle (*1a-6*) all the way forwards and lock it.
5. Look into the chamber. There must not be any cartridge in the chamber (*25a-C*). If there is a cartridge in the chamber, then a fault is present (*Section 10*).
6. Push bolt catch/release (*1a-4*). The bolt group snaps forwards.
7. Click safety lever (*1a-8*) to the “Single fire” position.
8. Pull trigger (*1a-9*). The hammer is released.
9. Click safety lever to the “Safe” position.

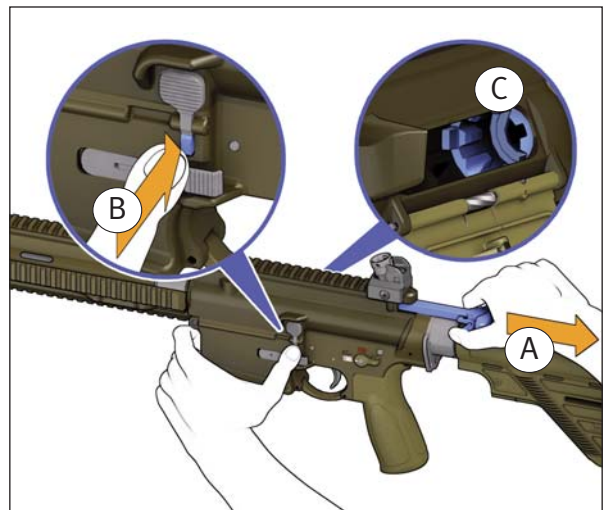

Fig. 25a: Carrying out a safety check

## 6.2 Carrying out a function check



Successful completion of a function check verifies that the weapon is functional. The function check is especially important after assembly of the weapon and after rectification of faults.

---

1. Carrying out a safety check (*Section 6.1*).
2. Move charging handle (*Ia-6*) backwards and forwards all the way several times.
3. Let charging handle snap forwards.
4. Click safety lever (*Ia-8*) to the “Safe” position.
5. Pull trigger (*Ia-9*). The hammer is not released.
6. Click safety lever to the “Single fire” position.
7. Pull trigger and hold it. The hammer is released.
8. Pull charging handle all the way back and then forwards.
9. Release trigger. The disconnecter releases the hammer.
10. Pull trigger. The hammer is released.
11. Insert empty magazine (*Ia-10*) into the weapon until the magazine catch (*IIa-7*) engages.
12. Verify that the magazine is firmly seated. »

13. Pull charging handle back all the way. The bolt group is held in the open position by the bolt catch/release (*la-4*).

**⚠ CAUTION**

**Risk of injury when the bolt group snaps forwards!**

**The bolt group snaps forwards when the bolt catch/release is pushed.**

- › Do not reach into the path of the bolt group.

14. Push charging handle all the way forwards and lock it.
15. Push bolt catch/release. The bolt group snaps forwards.
16. Remove magazine (*Section 8.5*).
17. Pull trigger and hold it. The hammer is released.
18. Click safety lever to the “Safe” position.
19. Verify that the flash hider (*la-11*) is firmly seated. Tighten with  $45 \pm 5$  Nm torque if necessary.

## 7 Preparations

### 7.1 Adjusting the buttstock



The buttstock can be locked in 5 positions.

1. Press buttstock locking lever and hold it (28a-A).
2. Slide buttstock to the desired position (28a-B).
3. Release buttstock release lever (11a-10).
4. Slide buttstock (11a-1) until it locks in the desired position.

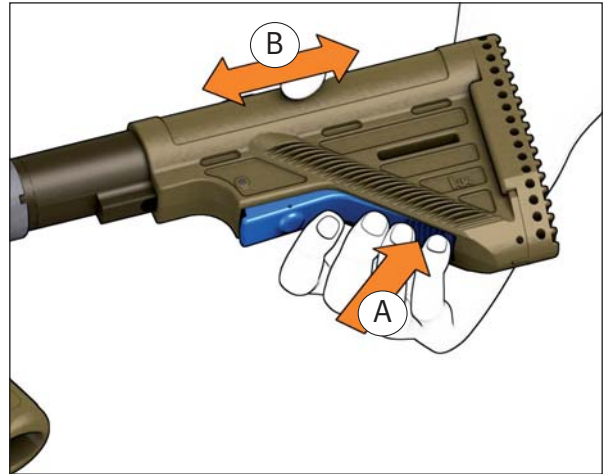

Fig. 28a: Adjusting the buttstock

## 7.2 Adjusting the buttstock MR308 A3 28

*Required auxiliary materials:*

- 4 mm Allen key



The buttstock can be locked 4 positions.

1. Insert Allen key in threaded pin.
2. Loosen threaded pin by turning anti-clockwise using Allen key.
3. Press release lever for buttstock (*I/a-10*) and hold it.
4. Slide buttstock (*I/a-1*) to desired position. »



Abb. 29a: Inserting the Allen key in the threaded pin

5. Release the release lever for buttstock.
6. Slide buttstock until it locks in desired position.
7. Tighten threaded pin by turning clockwise (29a-A).



The buttstock is fixed and can no longer be moved.

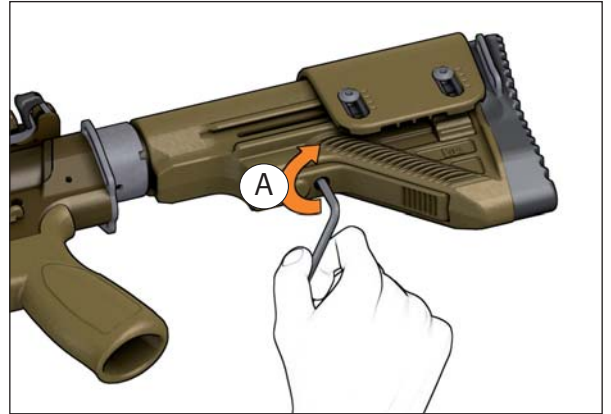

The extension wheel is used to make fine adjustments of the buttstock cap.

8. Turn extension wheel clockwise to extend buttstock cap (30a-A).
9. Turn extension wheel anti-clockwise to reduce buttstock cap (30a-A).



Abb. 30a: Turning the extension wheel



### 7.2.1 Adjusting the height of the cheek rest

*Required auxiliary materials:*

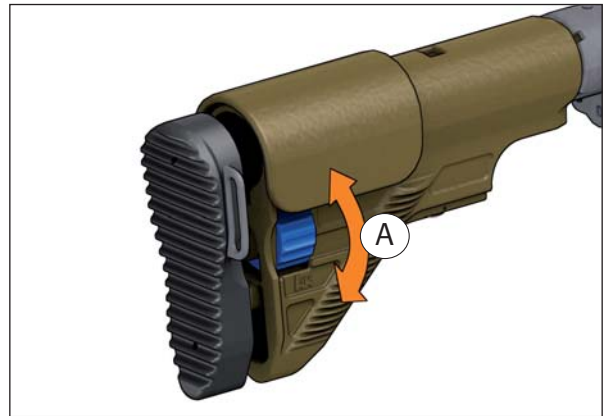
- 3 mm Allen key

1. Insert Allen key in screw.
2. Loosen both screws by turning anti-clockwise using Allen key (31a-A).
3. Slide cheek rest to desired position (31 a-B).
4. Tighten screws by turning clockwise using Allen key.



Abb. 31a: Sliding the cheek rest to the desired position

### 7.2.2 Removing the cheek rest

*Required auxiliary materials:*

- 3 mm Allen key

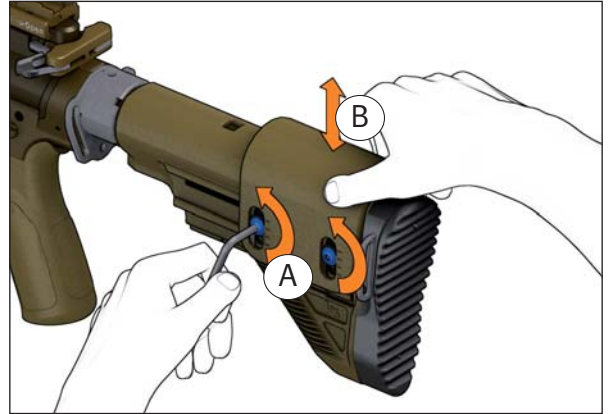
1. Insert Allen key in screw.
2. Loosen screws by turning anti-clockwise using Allen key (32a-A).
3. Remove screws.
4. Remove cheek rest (32a-B).



Abb. 32a: Removing the cheek rest

## 7.3 Adjusting the sights

### 7.3.1 Adjusting the drum sight

*Required auxiliary materials:*

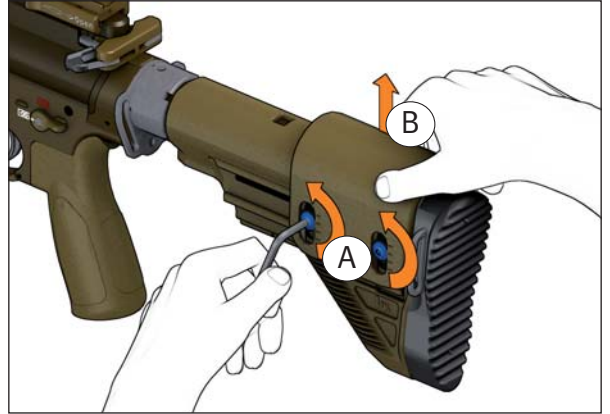
- *Screwdriver and elevation adjustment tool (Ident.-No. 300 009)*





The point of impact also depends on the ammunition. The use of different types of ammunition can change the elevation and windage of the point of impact. The sights can be adjusted to correct for the changed point of impact.



---



The following information refers to the drum sight (Ident.-No. 227 635 and Ident.-No. 227 666) together with the folding front sight (Ident.-No. 236 305 and Ident.-No. 233 210). The drum sight and the folding front sight can be obtained from specialist dealers using the specified Ident.-Nos..

---

Position of point of impact	Corrective measures	Information
	<ol style="list-style-type: none"> <li>1. Insert elevation adjustment tool (35a-2) in rear sight cylinder, inserting the wedges of elevation adjustment tool into the grooves of the rear sight cylinder.</li> <li>2. Insert screwdriver (35a-1) into elevation adjustment tool.</li> <li>3. Press screwdriver downwards and hold it (35a-A).</li> <li>4. Turn rear sight cylinder anti-clockwise (35a-B).</li> </ol>	<p>Turning the rear sight cylinder by one detent changes the point of impact by approx. 1.4 cm at a range of 100 m.</p> <p>Remove screwdriver and elevation adjustment tool from rear sight cylinder.</p>
	<ol style="list-style-type: none"> <li>1. Insert elevation adjustment tool (35a-2) in rear sight cylinder, inserting the wedges of elevation adjustment tool into the grooves of the rear sight cylinder.</li> <li>2. Insert screwdriver (35a-1) into elevation adjustment tool.</li> <li>3. Press screwdriver downwards and hold it (35a-A).</li> <li>4. Turn rear sight cylinder clockwise (35a-B).</li> </ol>	<p>Turning the rear sight cylinder by one detent changes the point of impact by approx. 1.4 cm at a range of 100 m.</p> <p>Remove screwdriver and elevation adjustment tool from rear sight cylinder.</p>

Position of point of impact	Corrective measures	Information
	<ol style="list-style-type: none"> <li>1. Loosen screw by turning anti-clockwise with screwdriver (35-1) (35b).</li> <li>2. Turn windage adjustment screw clockwise (35c).</li> <li>3. Tighten screw by turning clockwise with screwdriver.</li> </ol>	Turning the windage adjustment screw by one turn changes the mean point of impact by approx. 5.5 cm at a range of 100 m.
	<ol style="list-style-type: none"> <li>1. Loosen screw by turning anti-clockwise with screwdriver (35a-1) (35b).</li> <li>2. Turn windage adjustment screw anti-clockwise (35c).</li> <li>3. Tighten screw by turning clockwise with screwdriver.</li> </ol>	

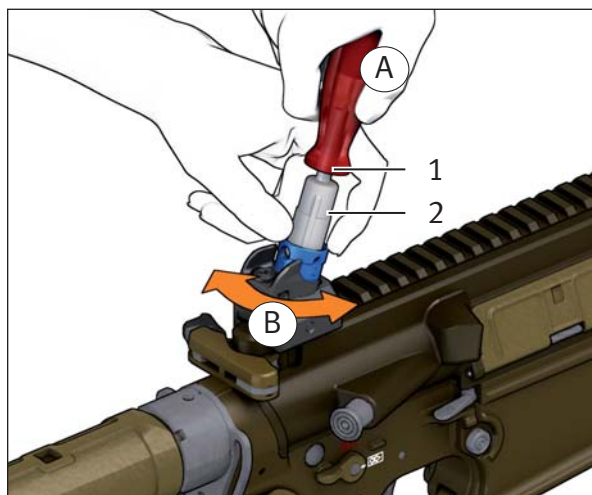

Fig. 35a: Inserting the rear sight adjusting tool

- 1 Screwdriver
- 2 Elevation adjustment tool

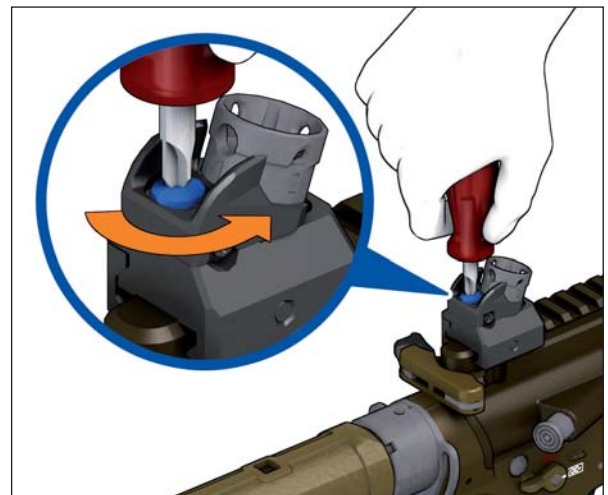

Fig. 35b: Loosening the screw

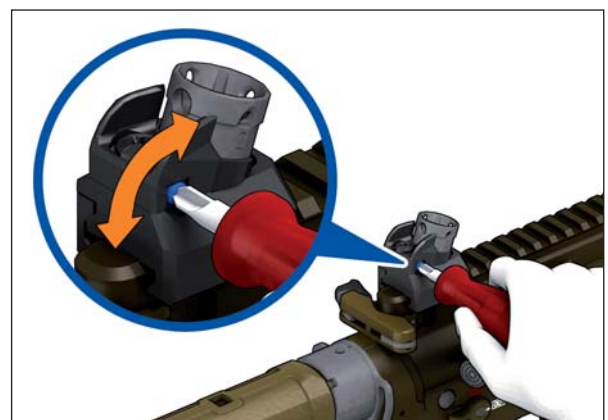

Fig. 35c: Turning the windage adjustment screw

### 7.3.2 Adjusting the quick change sight



The point of impact also depends on the ammunition. The use of different types of ammunition can change the elevation and windage of the point of impact. The rear sights can be adjusted to correct for the changed point of impact.

Position of point of impact	Corrective measures	Information
	<ol style="list-style-type: none"> <li>1. Raise dioptré (36a-A).</li> <li>2. Turn dioptré in direction “D” (Down) (36a-B).</li> </ol>	Turning the dioptré by a half turn changes the point of impact by approx. 4 cm at a range of 100 m.
	<ol style="list-style-type: none"> <li>1. Raise dioptré (36a-A).</li> <li>2. Turn dioptré in direction “U” (Up) (36a-B).</li> </ol>	
	<ol style="list-style-type: none"> <li>1. Press safety button for windage adjustment screw (36b-A).</li> <li>2. Turn windage adjustment screw in direction “L”(Left) (36b-B).</li> </ol>	Turning the windage adjustment screw by a quarter-turn changes the point of impact by approx. 3 cm at a range of 100 m.
	<ol style="list-style-type: none"> <li>1. Press safety button for windage adjustment screw (36b-A).</li> <li>2. Turn windage adjustment screw in direction “R” (Right) (36b-B).</li> </ol>	

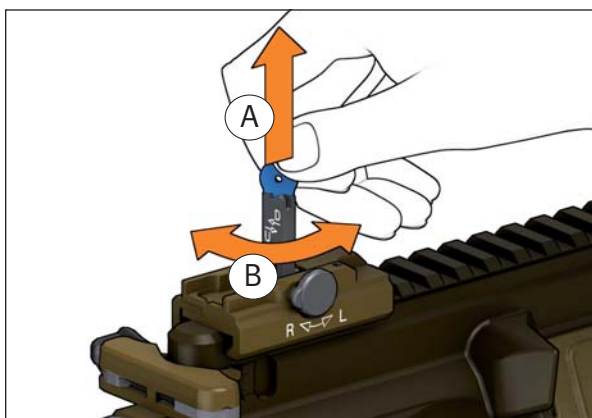

Fig. 36a: Turning the dioptré

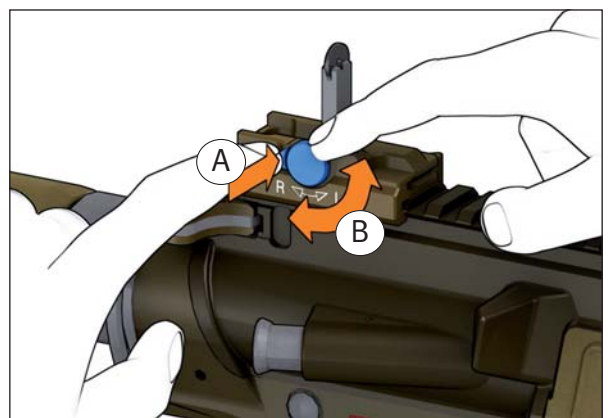

Fig. 36b: Turning windage adjustment screw

## 7.4 Filling the magazine

### NOTICE

**Risk of material damage due to damaged or fouled cartridges!**

**Damaged or fouled cartridges can damage the weapon and cause malfunctions.**

› Do not use damaged or fouled cartridges.

### NOTICE

**Risk of material damage from an overfilled magazine!**

**An overfilled magazine can lead to malfunctions.**

› Do not fill the magazine with more than the number of cartridges indicated on the magazine.

### NOTICE

**Risk of material damage from keeping a magazine filled for long periods!**

**Keeping a magazine filled for long periods can result in damage to the magazine spring and cause malfunctions.**

› Empty the magazine before you place the weapon and magazine in storage (Section 8.8).

1. Grasp magazine (1a-10).
2. Push cartridge under the magazine lips (1a-13) (37a-A).
3. Push cartridge to the rear as far as it will go (37a-B).
4. Repeat steps 2. - 3. until the magazine is full.

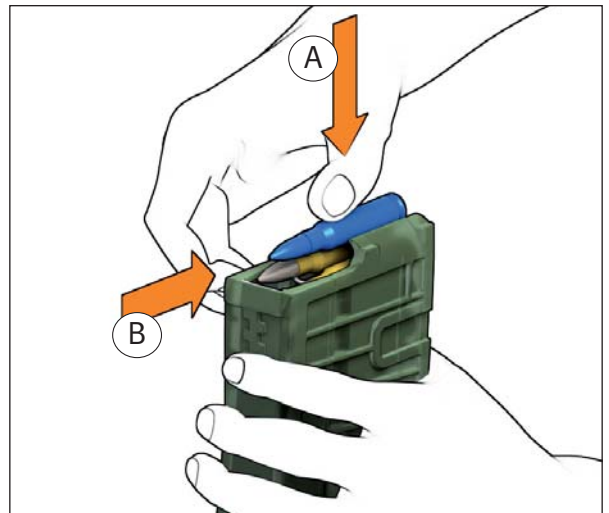

Fig. 37a: Filling the magazine

## 7.5 Preparing the weapon for firing

### 7.5.1 Preparing weapon with minimum cleaning kit for firing

*Required auxiliary materials:*

- *Cleaning pull-throughs*
  - *Minimum cleaning kit*
1. Disassemble the weapon (*Section 9.2*).
  2. Screw together handle, rotatable (*18a-7*), extension rods (*18a-5*) and pull-through holder (*18a-6*).
  3. Place clean cleaning pull-throughs (*18a-8*) in pull-through holder.

#### **NOTICE**

**Risk of material damage from incorrect cleaning direction!**

**It is forbidden to clean the barrel from the muzzle end of the weapon. Cleaning the barrel from the muzzle end of the weapon damages the barrel and decreases accuracy.**

› Always clean the barrel starting from the chamber end.

4. Push clean cleaning pull-throughs through the barrel several times from the chamber end to the muzzle until the barrel is free of oil and foreign bodies.
5. Visually check the weapon for damage.
6. Assemble the weapon (*Section 9.4*).
7. Carry out function check (*Section 6.2*).



## 7.5.2 Preparing weapon with maximum cleaning kit for firing

*Required auxiliary materials:*

- *Cleaning pull-throughs*
- *Maximum cleaning kit*

1. Disassemble the weapon (*Section 9.2*).
2. Screw together handle, rotatable (*19a-10*) and extension rods (*19a-8*).

### **NOTICE**

#### **Risk of material damage from incorrect cleaning direction!**

**It is forbidden to clean the barrel from the muzzle end of the weapon. Cleaning the barrel from the muzzle end of the weapon damages the barrel and decreases accuracy.**

› Always clean the barrel starting from the chamber end.

3. Insert handle, rotatable and extension rods in cleaning rod guide (*19a-13*).
4. Screw pull-through holder (*19a-9*) and extension rods together.
5. Place clean cleaning pull-throughs (*19a-14*) in pull-through holder.
6. Push locking pin of cleaning rod guide (*58a-1*) in all the way to the left.
7. Insert cleaning rod guide with handle, rotatable, extension rods and pull-through holder with cleaning pull-throughs all the way into the receiver from the rear (*58a-A*).
8. Push locking pin of cleaning rod guide in all the way to the right (*58a-B*).
9. Push clean cleaning pull-throughs through the barrel several times from the chamber end to the muzzle until the barrel is free of oil and foreign bodies.
10. Push locking pin of cleaning rod guide in all the way to the left.
11. Remove cleaning rod guide from receiver.
12. Visually check the weapon for damage.
13. Assemble the weapon (*Section 9.4*).
14. Carry out function check (*Section 6.2*).

## 7.6 Additional preparations in unusual climatic conditions

---



High air humidity and ambient temperatures between -25 °C and +63 °C do not require any special measures.

---



In cold conditions, freezing condensation can compromise the functional reliability of the weapon. To prevent the formation of condensation, do not bring the weapon from cold conditions into warm conditions and shortly thereafter again into cold conditions.

---

*Required auxiliary materials:*

- *Oil*
  - *Low-temperature oil*
- 
- › When there are high concentrations of dust or temperatures above +63 °C, lubricate the lubrication points of the bolt group (56a) and the lubrication points of the functional elements (56b) more heavily.
  - › At temperatures below -25 °C, lubricate all moving parts with low-temperature oil.

## 8 Operation

### 8.1 Inserting the magazine

1. Fill magazine (*Section 7.4*).
2. Click safety lever (*Ia-8*) to the “Safe” position.
3. Insert filled magazine into the weapon until the magazine catch (*Ila-7*) engages.

### 8.2 Chambering a round

#### **WARNING**

**Risk of injury from accidental discharge of weapon!**

**A weapon with a round in the chamber is always a potential source of danger.**

- › Chamber a round only immediately before firing.
- › Unload the weapon immediately after firing (*Section 8.7*).

1. Insert magazine into weapon (*Section 8.1*).
2. Pull charging handle (*Ia-6*) all the way back.
3. Let charging handle snap forwards. The weapon now has a round in the chamber and is set to “Safe”.

## 8.3 Firing position and aiming

### 8.3.1 Firing position



The supported shoulder firing position is the most stable and provides the best probability of hitting.

#### **⚠ WARNING**

##### **Risk of injury from recoil!**

##### **The weapon's recoil can cause serious injury.**

- › When firing, pull the weapon firmly into your shoulder.
  - › Keep your eye at least 6 cm away from the rear sight when firing.
  - › Keep your hands out of the path of the bolt group when firing.
- 
- › Rest weapon on the handguard (*la-3*) or bipod.
  - › Do not rest weapon on the barrel (*la-1*) or magazine (*la-10*).

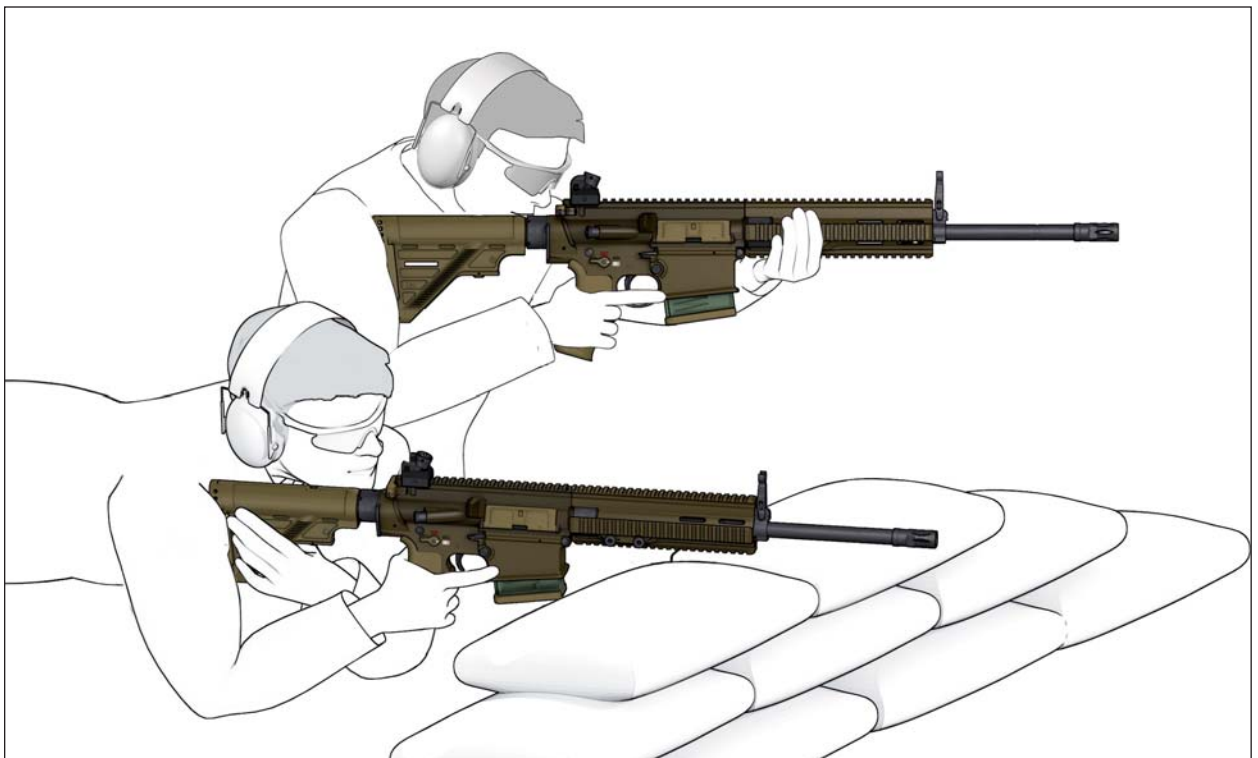
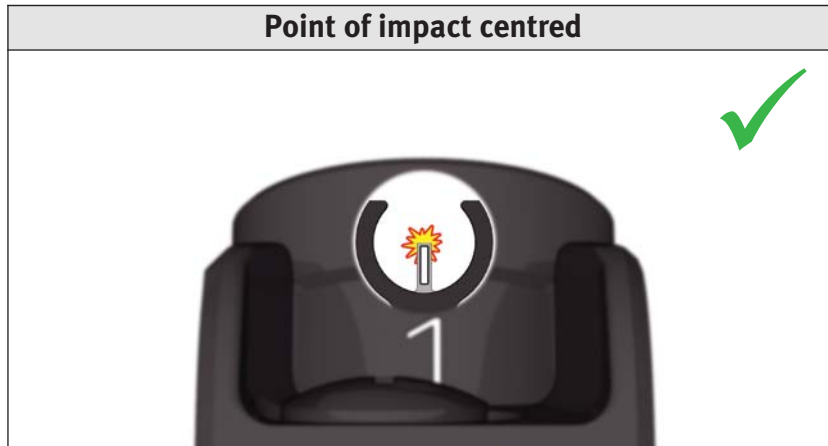

Fig. 42a: Firing position

### 8.3.2 Aiming with drum sight

- Correct aiming



- Aiming errors



### 8.3.3 Aiming with quick change sight

- Correct aiming

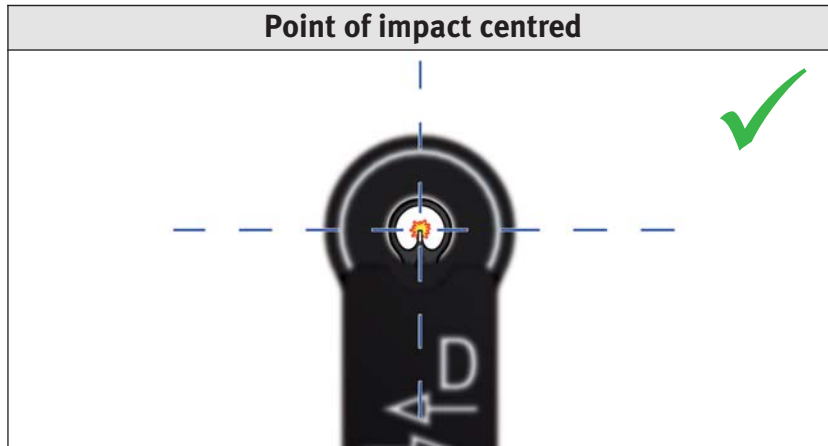

- Aiming errors



## 8.4 Firing



Follow safety instructions for firing (*Section 2.3*).

### 8.4.1 Firing in the “Single fire” position

1. Prepare weapon for firing (*Section 7.5*).
2. Chamber a round (*Section 8.2*).
3. Aim (*Section 8.3.2, Section 8.3.3*).
4. Click safety lever (*Ia-8*) to the “Single fire” position.

#### **WARNING**

##### **Risk of injury from recoil!**

##### **The weapon’s recoil can cause serious injury.**

- › When firing, pull the weapon firmly into your shoulder.
- › Keep your eye at least 6 cm away from the rear sight when firing.
- › Keep your hands out of the path of the bolt group when firing.

5. Pull trigger (*Ia-9*). A cartridge is fired.
6. After firing, or to reload, click safety lever to the “Safe” position.

## 8.5 Removing the magazine

1. Grasp magazine (*Ia-10*).

### **NOTICE**

**Risk of material damage from dropping the magazine!**

**Dropping the magazine can damage the magazine lips (*Ia-13*) and cause malfunctions.**

- › Remove the magazine by hand.
- › Avoid impacts on the magazine lips.

2. Press magazine catch (*IIa-7*).
3. Remove magazine.



## 8.6 Reloading the weapon

### **WARNING**

**Risk of injury from accidental discharge of weapon!**

**A weapon with a round in the chamber is always a potential source of danger.**

- › Chamber a round only immediately before firing.
- › Unload the weapon immediately after firing (*Section 8.7*).



After the last cartridge in the magazine is fired, the bolt catch/release holds the bolt group in the open position.

1. Remove magazine (*Section 8.5*).
2. Insert magazine into weapon (*Section 8.1*).
3. Push bolt catch/release (*1a-4*). The bolt group snaps forwards. The weapon now has a round in the chamber and is set to “Safe”.

## 8.7 Unloading the weapon

1. Remove magazine (*Section 8.5*).
2. Pull charging handle (*1a-6*) all the way back and hold it. A cartridge is ejected.
3. Push bolt catch/release (*1a-4*) and hold it. »

4. Push charging handle all the way forwards and lock it.

**⚠ CAUTION****Risk of injury when the bolt group snaps forwards!****The bolt group snaps forwards when the bolt catch/release is pushed.**

- › Do not reach into the path of the bolt group.

5. Look into the chamber. There must not be any cartridge in the chamber. If there is a cartridge in the chamber, then a fault is present (*Section 10*).
6. Push bolt catch/release. The bolt group snaps forwards.
7. Click safety lever (*1a-8*) to the “Single fire” position.
8. Pull trigger (*1a-9*). The hammer is released.
9. Click safety lever to the “Safe” position.

## 8.8 Empty the magazine

**⚠ WARNING****Risk of injury from igniting the cartridges!****Impacts to the primer can ignite the cartridge.**

- › Push the cartridges into your hand when you empty the magazine.
  - › Prevent any impacts to the primer.
  - › Prevent cartridges from falling.
- 
- › Push cartridges forwards out of the magazine (*1a-10*).

## 9 Cleaning

### 9.1 General instructions for cleaning



Regular cleaning and care of the weapon and accessories

- maintain functional reliability,
- increase service life,
- prevent accidents, and
- save repair costs and time.

- › Clean weapon each time it is fired and at intervals of 1000 rounds.

#### **NOTICE**

**Risk of material damage from the use of excessive force!**

**The use of excessive force during disassembly, cleaning and assembly can damage the weapon.**

- › Do not use excessive force when disassembling, cleaning and assembling the weapon.

### 9.2 Disassembling the weapon

#### **⚠ WARNING**

**Risk of injury from improperly assembled weapon!**

**Improper assembly can compromise the safety and functioning of the weapon.**

- › Only disassemble the weapon to the extent described in this manual.

### 9.2.1 Disassembling the weapon into assembly groups

*Required auxiliary materials:*

- 5 mm Allen key
1. Carry out safety check (*Section 6.1*).
  2. Press rear locking pin (*I/a-8*) in to the right and pull out as far as disassembly position.
  3. Fold lower receiver downwards.
  4. Press front locking pin (*I/a-6*) in to the right and pull out as far as disassembly position.
  5. Remove lower receiver. »

6. Press buffer into the buttstock and hold it (51a-A).
7. Press locking pin for buffer in and hold it (51a-B).
8. Pull buffer and recoil spring forwards out of the buttstock (IIa-1).
9. Pull charging handle (Ia-6) back.
10. Remove bolt group from upper receiver.
11. Remove charging handle from upper receiver.
12. Fold front sight (Ia-2) downwards.
13. Unscrew locking screws for handguard anti-clockwise with the Allen key and pull out to disassembly position (51b).
14. Pull handguard (Ia-3) forwards off barrel (Ia-1).

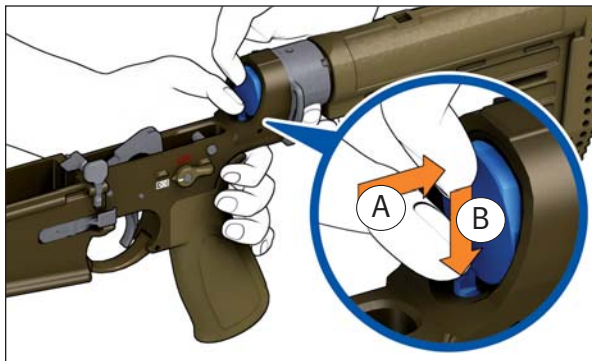

Fig. 51a: Pushing in locking pin for buffer

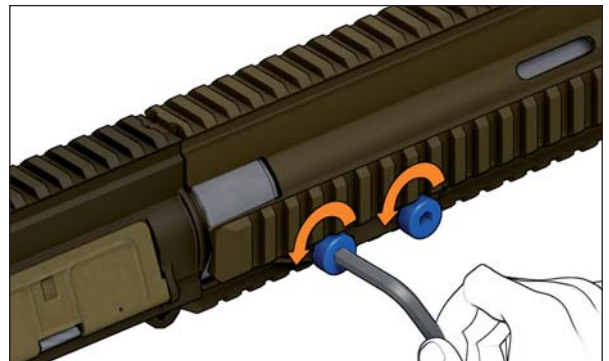

Fig. 51b: Unscrewing locking screws for handguard

### 9.2.2 Disassembling parts of the gas drive

1. Disassemble the weapon into assembly groups (*Section 9.2.1*).
2. Pull rod (52a-3) to rear and hold it.
3. Pull rod upwards and forwards out of upper receiver (52a).
4. Remove gas piston (52a-2) from gas block (52a-1).

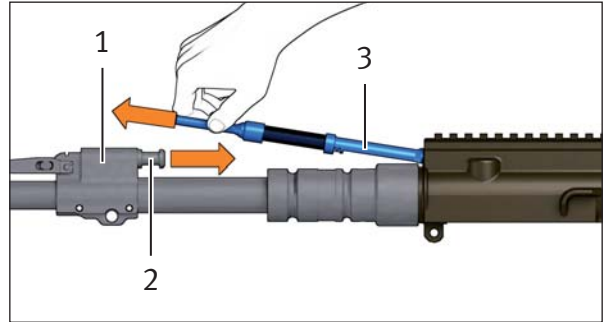

Fig. 52a: Removing the rod

- 1 Gas block
- 2 Gas piston
- 3 Rod

### 9.2.3 Disassembling the bolt group

1. Disassemble the weapon into assembly groups (*Section 9.2.1*).
2. Push locking pin (*53a-7*) into the bolt head carrier (*53a-3*) from the right.
3. Pull locking pin out of the bolt head carrier to the left as far as it will go.
4. Lift firing pin safety (*53a-4*).
5. Take firing pin (*53a-6*) and pressure spring for firing pin (*53a-5*) to the rear and out of the bolt head carrier.
6. Pull control bolt (*53a-2*) out of bolt head (*53a-1*).
7. Pull bolt head out of bolt head carrier.

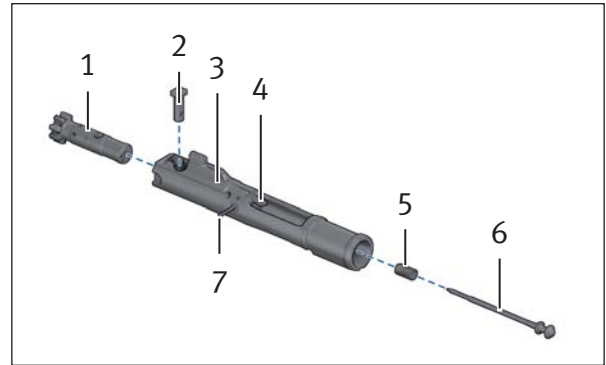

Fig. 53a: Components of the bolt group

- 1 Bolt head
- 2 Control bolt
- 3 Bolt head carrier
- 4 Firing pin safety
- 5 Pressure spring for firing pin
- 6 Firing pin
- 7 Locking pin

## 9.3 Cleaning the weapon

### 9.3.1 Cleaning the weapon with minimum cleaning kit

*Required auxiliary materials:*

- *Minimum cleaning kit*
- *Oil*
- *Cleaning rag*



Clean the barrel from the chamber to the muzzle.

---

#### **NOTICE**

**Risk of material damage from incorrect cleaning agents and care products!**

**Incorrect cleaning agents and care products can damage the weapon.**

- › When cleaning the weapon, use the specified cleaning agents.
- › Do not use any metallic objects, plastics (nylon, etc.) or chemical cleaning agents (benzine, tetrachlorethylene, trichlor, etc.) to clean the weapon.
- › Do not clean the weapon in an ultrasonic bath.

1. Disassemble the weapon (*Section 9.2*).
2. Visually check the weapon for damage.
3. Clean fouled parts and surfaces using cleaning rag.
4. Oil cleaned metal parts thinly.
5. Screw together handle, rotatable (*18a-7*), two extension rods (*18a-5*) and chamber cleaning brush (*18a-2*).
6. Clean chamber and barrel extension using chamber cleaning brush. »



7. Screw together handle, rotatable, extension rods and barrel cleaning brush (18a-3).

**NOTICE**

**Risk of material damage if the barrel cleaning brush is not pulled completely through the barrel!**

**Not pulling the barrel cleaning brush completely through the barrel can damage the inside of the barrel and decrease accuracy.**

- › Push the barrel cleaning brush completely through the barrel starting from the chamber end. This allows the bristles of the barrel cleaning brush to straighten out again. Pull the barrel cleaning brush out of the chamber to the rear in an extension of the barrel bore axis.

**NOTICE**

**Risk of material damage from incorrect cleaning direction!**

**It is forbidden to clean the barrel from the muzzle end of the weapon. This damages the barrel and decreases accuracy.**

- › Always clean the barrel starting from the chamber end.

8. Push lubricated barrel cleaning brush completely through the barrel (1a-1) several times.
9. Replace barrel cleaning brush with pull-through holder (18a-6).
10. Place clean cleaning pull-throughs (18a-8) in pull-through holder.
11. Push clean cleaning pull-throughs through the barrel several times from the chamber end to the muzzle until the barrel is free of oil and foreign bodies.
12. Replace pull-through holder with oil brush (18a-4). »

13. Pull lubricated oil brush through the barrel.
14. Lubricate lubrication points of the bolt group (56a).
15. Lubricate lubrication points of the functional elements (56b).

**NOTICE**

**Risk of material damage from lubricated cartridges!**

**Lubricated cartridges result in increased loads on components and can lead to premature wear on the weapon.**

- › Do not lubricate the inside of the magazine.

16. Clean magazine (1a-10) and follower (1a-12) using cleaning cloth.
17. Assemble the weapon (Section 9.4).

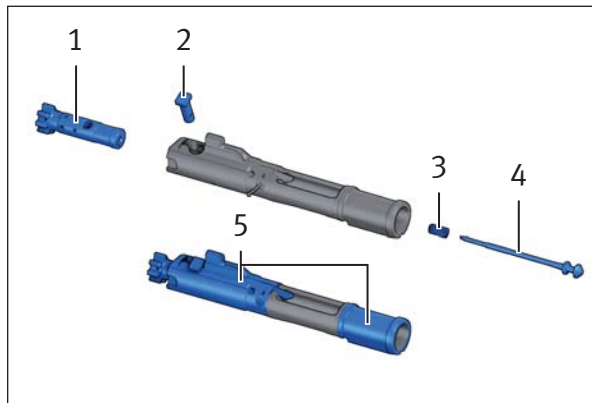

Fig. 56a: Lubrication points of the bolt group

- 1 Bolt head
- 2 Control bolt
- 3 Pressure spring for firing pin
- 4 Firing pin
- 5 Operating surfaces of the bolt group

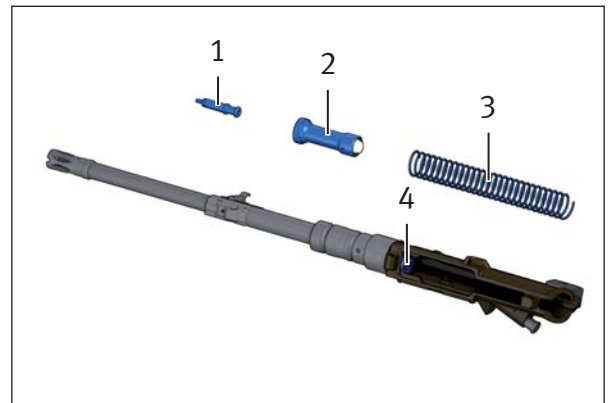

Fig. 56b: Lubrication points of the functional elements

- 1 Gas piston
- 2 Buffer
- 3 Recoil spring
- 4 Barrel extension

### 9.3.2 Cleaning the weapon with maximum cleaning kit

*Required auxiliary materials:*

- Oil
- Maximum cleaning kit



Clean the barrel from the chamber to the muzzle.

#### **NOTICE**

**Risk of material damage from incorrect cleaning agents and care products!**

**Incorrect cleaning agents and care products can damage the weapon.**

- › When cleaning the weapon, use the specified cleaning agents.
- › Do not use any metallic objects, plastics (nylon, etc.) or chemical cleaning agents (benzine, tetrachlorethylene, trichlor, etc.) to clean the weapon.
- › Do not clean the weapon in an ultrasonic bath.

1. Disassemble the weapon (*Section 9.2*).
2. Visually check the weapon for damage.
3. Clean fouled parts and surfaces using cleaning cloth (*19a-20*).
4. Oil cleaned metal parts thinly.
5. Screw together T-handle (*19a-18*), two extension rods (*19a-8*) and cleaning brush for chamber and barrel extension (*19a-7*).
6. Clean chamber and barrel extension using cleaning brush for chamber and barrel extension. »

7. Screw together handle, rotatable (19a-10) and extension rods.
8. Insert handle, rotatable and extension rods in cleaning rod guide (19a-13).
9. Screw together barrel cleaning brush (19a-5) and extension rods.
10. Push locking pin of cleaning rod guide (58a-1) in all the way to the left.

#### NOTICE

**Risk of material damage if the barrel cleaning brush is not pulled completely through the barrel!**

**Not pulling the barrel cleaning brush completely through the barrel can damage the inside of the barrel and decrease accuracy.**

- › Push the barrel cleaning brush completely through the barrel starting from the chamber end. This allows the bristles of the barrel cleaning brush to straighten out again. Pull the barrel cleaning brush out of the chamber to the rear in an extension of the barrel bore axis.

#### NOTICE

**Risk of material damage from incorrect cleaning direction!**

**It is forbidden to clean the barrel from the muzzle end of the weapon. This damages the barrel and decreases accuracy.**

- › Always clean the barrel starting from the chamber end.

11. Insert cleaning rod guide with handle, rotatable, extension rods and barrel cleaning brush all the way into the receiver from the rear (58a-A).
12. Push locking pin of cleaning rod guide in all the way to the right (58a-B). »

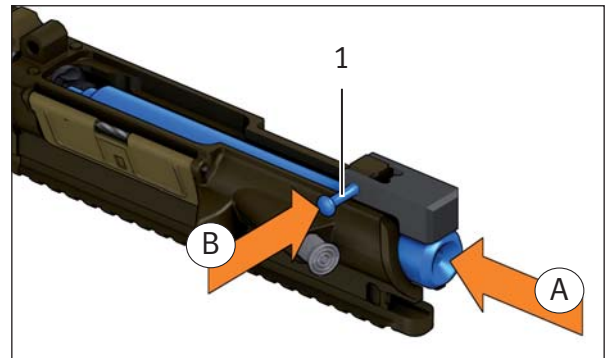

Fig. 58a: Pushing in locking pin for cleaning rod guide

1 Locking pin for cleaning rod guide

13. Push lubricated barrel cleaning brush completely through the barrel (*1a-1*) several times.
14. Push locking pin of cleaning rod guide in to the left and pull it out as far as it will go.
15. Remove cleaning rod guide with handle, rotatable from upper receiver.
16. Replace barrel cleaning brush with pull-through holder (*19a-9*).
17. Place clean cleaning pull-throughs (*19a-14*) in pull-through holder.
18. Insert cleaning rod guide with handle, rotatable and pull-through holder with cleaning pull-throughs all the way into the upper receiver from the rear.
19. Push locking pin of cleaning rod guide in all the way to the right.
20. Push clean cleaning pull-throughs through the barrel several times until the barrel is free of oil and foreign bodies.
21. Push locking pin of cleaning rod guide in to the left and pull it out as far as it will go.
22. Remove cleaning rod guide with handle, rotatable from upper receiver.
23. Replace pull-through holder with oil brush (*19a-6*). »

24. Insert cleaning rod guide with handle, rotatable and oil brush all the way into upper receiver from the rear.
25. Push locking pin of cleaning rod guide in all the way to the right.
26. Pull lubricated oil brush through the barrel.
27. Push locking pin of cleaning rod guide in to the left and pull it out as far as it will go.
28. Remove cleaning rod guide with handle, rotatable from upper receiver.
29. Screw together handle, rotatable, two extension rods and cleaning brush for extension (19a-2).
30. Clean extension inside with lubricated cleaning brush for extension (60a).
31. Replace cleaning brush for extension with oil brush for extension (19a-3).
32. Lubricate extension inside with lubricated oil brush for extension.
33. Lubricate lubrication points of the bolt group (56a).
34. Lubricate lubrication points of the functional elements (56b).
35. Assemble the weapon (Section 9.4).

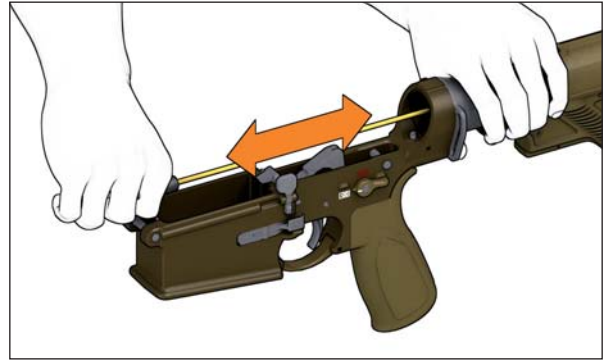

Fig. 60a: Cleaning the extension inside

## 9.4 Assembling the weapon

### 9.4.1 Assembling the bolt group

1. Insert bolt head into the bolt head carrier with the extractor to the right (61a).
2. Insert control bolt into bolt head carrier with the bore in the longitudinal direction (61a-A).
3. Push pressure spring for firing pin (53a-5) onto firing pin (53a-6).
4. Pull locking pin (53a-7) out of the bolt head carrier to the left as far as it will go.
5. Raise firing pin safety and hold it (61b-A).
6. Press firing pin and pressure spring for firing pin from the rear into the bolt head carrier as far as they will go and hold them (61b-B).
7. Insert locking pin from the left completely into the bolt head carrier (61b-C).

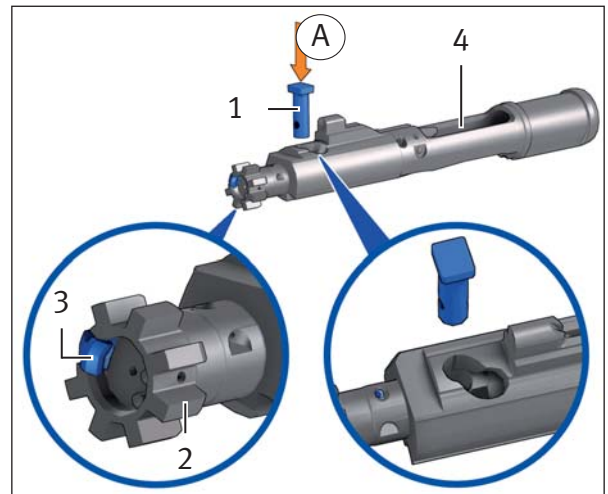

Fig. 61a: Inserting the control bolt

- 1 Control bolt
- 2 Bolt head
- 3 Extractor
- 4 Bolt head carrier

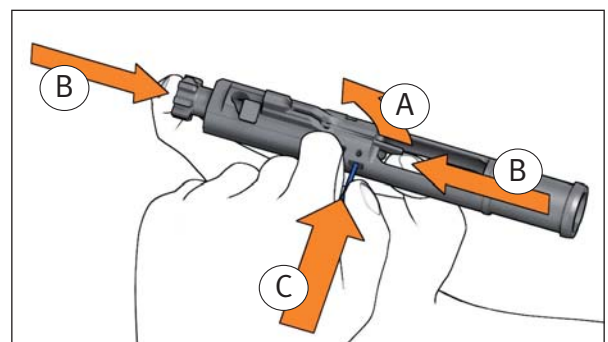

Fig. 61b: Pressing in the locking pin

### 9.4.2 Assembling parts of the gas drive

1. Insert gas piston (62a-2) into the gas block (62a-1).
2. Insert rod into upper receiver in assembly position (62a).
3. Press rod (62a-3) to the rear against spring force and insert in gas piston.

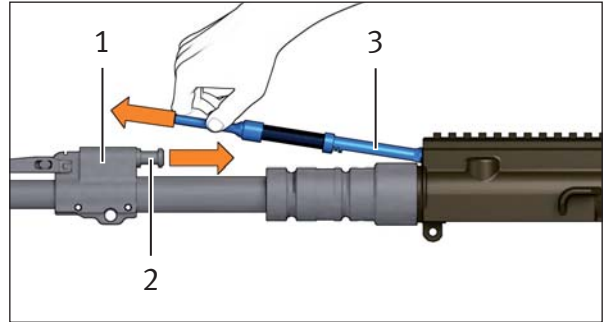

Fig. 62a: Assembly position of the rod

- 1 Gas block
- 2 Gas piston
- 3 Rod



### 9.4.3 Assembling the assembly groups

Required auxiliary materials:

- 5 mm Allen key
1. Assemble the bolt group (Section 9.4.1).
  2. Push handguard (Ia-3) onto the barrel (Ia-1) from the front as far as it will go.
  3. Insert locking screws for handguard (IIa-5).

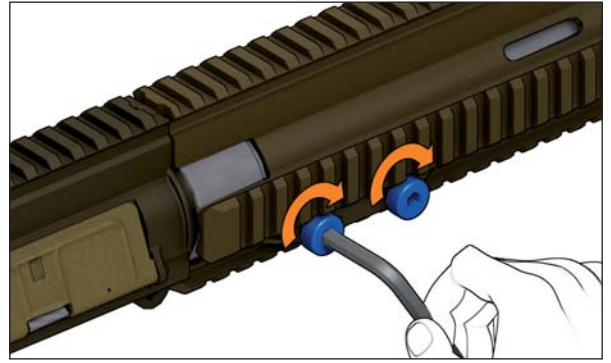

Fig. 63a: Tightening locking screws for handguard

#### NOTICE

**Risk of material damage through use of excessive torque!**

**The locking screws for handguard has a defined breaking point to prevent damage to the handguard. The locking screws for handguard breaks off at a torque of 14 Nm.**

- › When tightening the locking screws for handguard, keep within the torque.

»

4. Tighten locking screws for handguard clockwise with Allen key until the torque of  $8\pm 1$  Nm is reached (63a).



The bolt group can only be inserted into the weapon if the bolt head is in the forward position. Otherwise the control bolt blocks the bolt group from being inserted into the upper receiver.

5. Insert charging handle (1a-6) into recess in upper receiver and push forwards about 5 cm.
6. Pull bolt head (53a-1) forwards out of the bolt head carrier (53a-3) as far as it will go.
7. Insert guide cam of bolt group into guide groove of charging handle (64a).
8. Push bolt group (64a-2) all the way forwards until the charging handle locks.
9. Insert buffer into the recoil spring. »

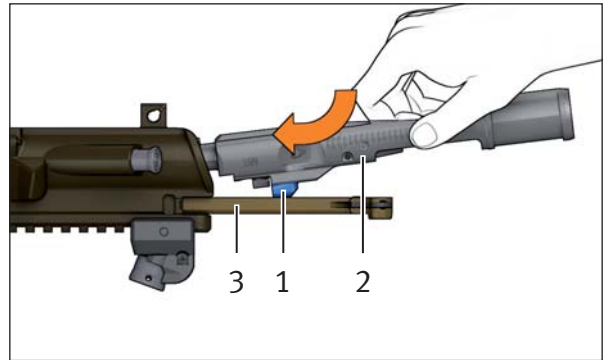
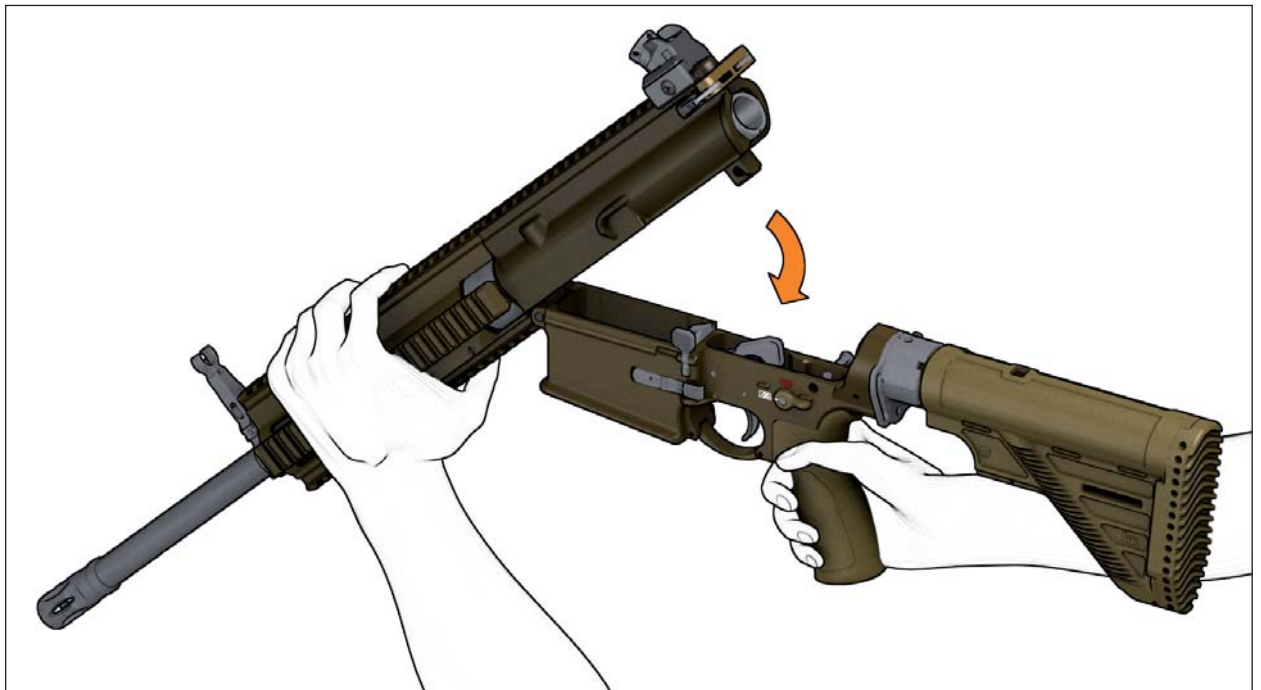

Fig. 64a: Inserting bolt group into charging handle

- 1 Guide cam of the bolt group
- 2 Bolt group
- 3 Guide groove of the charging handle

10. Insert buffer and recoil spring into the buttstock (*Ila-1*).
11. Push buffer behind the locking pin for buffer.
12. Using the front locking pin (*Ila-6*), insert lower receiver into front bore for locking pin of the upper receiver at an angle of about 45°.
13. Push front locking pin in all the way to the left.
14. Swing upper receiver down onto lower receiver as far as it will go (*65a*).
15. Push rear locking pin (*Ila-8*) in all the way to the left.
16. Carry out function check (*Section 6.2*).



*Fig. 65a: Assembling lower receiver and upper receiver*

## 10 Faults: Causes and remedies



Users are strictly prohibited from rectifying faults that go beyond the scope of this manual! Only authorised specialists may troubleshoot such faults in the weapon.

### **⚠ WARNING**

**Safety risk from not knowing whether or not the weapon is loaded!**

**In the event of a fault, the weapon may be loaded even if you expect that it is unloaded.**

- › In the event of a fault, treat the weapon as if there were a round in the chamber.
- › In the event of a fault, verify whether the weapon is actually loaded.
- › Follow the fundamental safety instructions (*Section 2*) for rectifying faults.

The following items do not constitute a complete list of all possible faults. Causes other than those named here are also possible.

Fault	Cause	Remedy
Bullet is stuck in the barrel.	Improperly loaded ammunition.	Send weapon in for repair.
Cartridge has not fired.	Defective ammunition.	Wait at least one minute. Unload weapon ( <i>Section 8.7</i> ). Do not re-use cartridges that have failed to fire.
	Firing pin sluggish, damaged or broken.	Send weapon in for repair.
	Hammer defective.	Send weapon in for repair.

Fault	Cause	Remedy
Bolt group does not open after firing.	Defective ammunition.	Unload weapon ( <i>Section 8.7</i> ). Clean weapon if necessary ( <i>Section 9.3</i> ). Send weapon in for repair if necessary.
	Gas drive fouled or defective.	Clean gas piston. Send weapon in for repair if necessary.
Cartridge or cartridge case is not ejected.	Cartridge rim ripped off.	Unload weapon ( <i>Section 8.7</i> ). Send weapon in for repair if necessary.
	Chamber is fouled.	Clean chamber.
	Rearward movement of bolt group too short.	Unload weapon ( <i>Section 8.7</i> ). Carry out function check ( <i>Section 6.2</i> ). Clean weapon if necessary ( <i>Section 9.3</i> ). Send weapon in for repair if necessary.
	Ammunition incorrectly loaded.	Use different ammunition.
	Extractor, pressure spring for extractor, ejector or pressure spring for ejector damaged.	Send weapon in for repair.
Cartridge is not loaded into the chamber.	Chamber is fouled.	Unload weapon ( <i>Section 8.7</i> ). Clean weapon ( <i>Section 9.3</i> ).
	Cartridge deformed.	Use different cartridge.
	Recoil spring defective.	Send weapon in for repair.

Fault	Cause	Remedy
Cartridge does not feed.	Magazine not correctly inserted.	Insert magazine correctly.
	Magazine spring defective.	Send magazine in for repair.
	Magazine or magazine lips damaged.	Use different magazine.
	Rearward movement of bolt group too short.	Unload weapon ( <i>Section 8.7</i> ). Carry out function check ( <i>Section 6.2</i> ). Clean weapon if necessary ( <i>Section 9.3</i> ). Send weapon in for repair if necessary.
Bolt group does not stay in open position after last round.	Magazine spring defective.	Send magazine in for repair.
	Rearward movement of bolt group too short.	Unload weapon ( <i>Section 8.7</i> ). Carry out function check ( <i>Section 6.2</i> ). Clean weapon if necessary ( <i>Section 9.3</i> ). Send weapon in for repair if necessary.
	Bolt catch/release damaged.	Send weapon in for repair.
	Ammunition incorrectly loaded.	Use different ammunition.

<b>Fault</b>	<b>Cause</b>	<b>Remedy</b>
Magazine sticks in magazine well.	Magazine damaged.	Exchange magazine. Send damaged magazine in for repair.
	Magazine catch defective.	Send weapon in for repair.
Windage or elevation of point of impact changed.	Sights misaligned.	Adjust sights ( <i>Section 7.3</i> ).
	Other type of ammunition.	Use another type of ammunition or adjust sights ( <i>Section 7.3</i> ).
	Sights damaged.	Send weapon in for repair.

## 11 Protection, packaging and storage



Protection guards the weapon against external influences and maintains its functional reliability even if it is not used for long periods. If the weapon is expected to be stored for more than 6 months, the weapon must be protected.

If the weapon is expected to be stored for not more than six months, it is sufficient to clean the weapon (*Section 9.3*).

---

### 11.1 Protecting the weapon

*Required auxiliary materials:*

- Grease
- Oil paper

1. Clean weapon (*Section 9.3*).
2. Seal both ends of the barrel (*la-1*) with grease.
3. Wrap weapon in oil paper.



## 11.2 Packaging the weapon

1. Unload weapon (*Section 8.7*).
2. Empty the magazine (*Section 8.8*).
3. Package the weapon in appropriate transport container.

## 11.3 Storing the weapon



Store the weapon and ammunition separately.

1. Follow applicable regulations for the storage of weapons and ammunition.
2. Whenever the weapon is expected to be stored for more than 6 months, protect the weapon (*Section 11.1*).
3. Whenever the weapon is not expected to be stored for more than 6 months, clean the weapon (*Section 9.3*).
4. Package the weapon (*Section 11.2*).
5. Store the weapon in an enclosed, weather resistant room.

### **WARNING**

#### **Risk of accidents caused by unauthorised persons!**

**Unauthorised persons who have no experience with weapons can cause accidents.**

- › Be sure to prevent access to the weapon and ammunition by unauthorised persons, especially children.

6. Protect rooms where weapons are stored against break-in and fire.

Whenever the weapon is stored for more than 1 year:

7. Check the grease seal on the barrel (*Ia-1*) and the oil film on the metal parts annually.

## 12 Transport and shipping

### 12.1 Preparing the weapon for transport

1. Package the weapon (*Section 11.2*).
2. Secure the weapon in vehicle.

#### **NOTICE**

##### **Risk of material damage from vibrations!**

##### **Vibrations during transport can damage the weapon.**

- › During transport, secure the transport container against slipping and damage from outside influences.
- › Avoid impacts and vibration of the weapon.

### 12.2 Transporting the weapon

---



Transport weapon and ammunition separately.

---

- › Follow applicable regulations for the transport of weapons and ammunition.

### 12.3 Shipping the weapon

---



Ship weapon and ammunition separately.

---

- › Follow applicable regulations for the shipping of weapons and ammunition.

## **13 Destruction and disposal**

### **13.1 Destroying the weapon**

- › Follow applicable regulations for the destruction of weapons and ammunition.

### **13.2 Disposing of the weapon**

- › Follow applicable regulations for the disposal of weapons and ammunition.







Rifle	MR308 A3 16,5"	MR308 A3 20"	MR308 A3 28
Calibre	.308 Win.		
Operating principle	Semi-automatic, gas-operated		
Bolt system	Locked rotating bolt head		
Cartridge feed	Magazine, 10 or 20 cartridges		
Cartridge case ejection	Right side		
Modes of fire	Single fire		
<b>Dimensions</b>			
Max. length	985 mm	1072 mm	992 mm
Min. length	905 mm	992 mm	925 mm
Width	78 mm	78 mm	78 mm
Height <sub>1</sub>	197 mm	197 mm	197 mm
Barrel length <sub>2</sub>	421 mm	508 mm	421 mm
Sight radius	435 mm	505 mm	514 mm
<b>Weight</b>			
Weapon without magazine <sub>1</sub>	approx. 4370 g	approx. 4465 g	approx. 5090 g
Magazine, 10 cartridge (full) <sub>3</sub>	approx. 360 g		
Magazine, 10 cartridge (empty)	approx. 110 g		
<b>Other data</b>			
Trigger pull			
Muzzle velocity -v <sub>0-3</sub>	approx. 730 m/s	approx. 750 m/s	approx. 730 m/s
Muzzle energy -E <sub>0-3</sub>	approx. 2800 J	approx. 3000 J	approx. 2800 J
Barrel profile / twist / compliance	Groove/land profile, 4 grooves / right-hand twist / C.I.P		

<sub>1</sub> without rear sight / front sight folded down

<sub>2</sub> without flash hider

<sub>3</sub> SWISS P Target 167gr HPBT ammunition

## Technical data



---

# No Compromise

---

Quality . Innovation . Service . Safety



**Heckler & Koch GmbH**  
**Heckler & Koch-Str. 1**  
**78727 Oberndorf/N.**  
**Germany**

**Telephone:** +49 (0) 74 23 / 79-0  
**Fax:** +49 (0) 74 23 / 79-23 50  
**E-mail:** [TD@heckler-koch-de.com](mailto:TD@heckler-koch-de.com)  
**Internet:** [www.heckler-koch.com](http://www.heckler-koch.com)

Copyright © 2014  
Made in Germany  
Version 001.1114

