

YL12-1J2

PUMP SHOTGUN

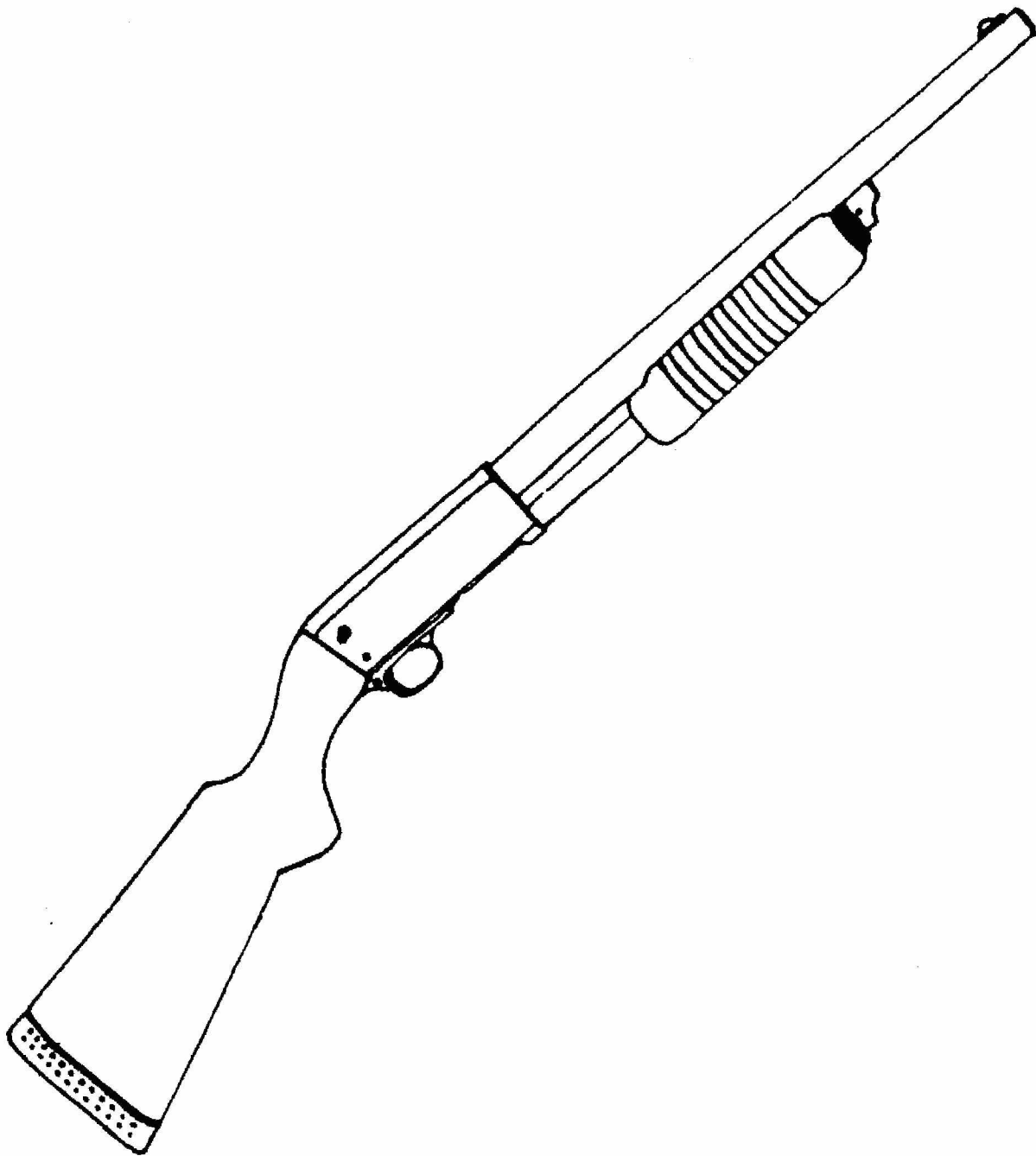

INSTRUCTION MANUAL

V. Parts List

No.	Names	QTY	No.	Names	QTY	No.	Names	QTY
1	Fire Pin	1	25	Receiver	1	49	Hoop	1
2	Fire Pin Spring	1	26	Firing Gear Support Screw	1	50	Hammer Spring Rod	1
3	Bolt	1	27	Left Stop pawl	1	51	Pin	1
4	Upper Extractor Spring	1	28	Left Stop Pawl Pin	1	52	Hammer	1
5	Bar Post	1	29	Follower	1	53	Hammer Pin	1
6	Upper Extractor	1	30	Right Stop Pawl	1	54	Firing Gear Support	1
7	Fire Pin Peg	1	31	Stop Pawl Spring	2	55	Sliding Lock	1
8	Lower Extractor Pin	1	32	Right Stop Pawl Pin	1	56	Retaining Pin	1
9	Lower Extractor Spring	1	33	Barrel	1	57	Sliding Lock Spring	1
10	Lower Extractor	1	34	Front Sight	1	58	Torsion Spring	1
11	Spring Post	1	35	Collar	1	59	Safety Bar-post Spring	1
12	Connecting Shaft Pin	2	36	Screw	1	60	Bar Post	1
13	Return Spring	1	37	Locating Seat	1	61	Safety	1
14	Connecting Shaft	2	38	Bar Post	1	62	Hammer Spring Sleeve	1
15	Bolt Frame	1	39	Locating Spring	1	63	Hammer Spring	1
16	Screw	2	40	Screw	1	64	Spring Seat	1
17	Butt Plate	1	41	Magazine	1	65	Spring Seat Pin	1
18	Washer Plate	1	42	Magazine Spring Cap	1	66	Trigger pin	1
19	Stock	1	43	Magazine Spring	1	67	Trigger Spring	1
20	Stock Long Screw	1	44	Locking Nut	1	68	Trigger	1
21	Disk Spring	4	45	Right Pulling Lever	1	69	Sear Pin	1
22	Washer	1	46	Left Pulling Lever	1	70	Sear Spring	1
23	Screw	2	47	Sliding Sleeve	1	71	Sear	1
24	Follower Screw	2	48	Forend	1			

YL12—1J2

YL12—1J2 pump shotgun has the advantages of elegant shape, high accuracy in firing, safe and reliable operations. It is easy to assemble and disassemble. The shotgun has the capability of using 12 gauge standard shells. It is suitable for hunting and sporting.

I. Main Technical Data

Gauge	12
Chamber Length(mm)	70
Effective Range(m)	50
Barrel Length(mm)	483
Choke	140
Length of Pull(mm)	355
Drop at Comb(mm)	40
Drop at Heel(mm)	65
Magazine Capacity(round)	5(including a round in the chamber)
Trigger Pull(N)	15~30
Complete Weight(kg)	3.3
Overall Length(mm)	1248
Service Life(round)	≥5000

II. Main Structure and Operating Principles

1. Main structure:

The shotgun mainly consists of the follows:(Fig. 1)

1. barrel
2. forend
3. bolt
4. bolt frame
5. firing gear group
6. receiver
7. stock
8. stock long screw
9. follower
10. left, right stop pawl
11. locking nut

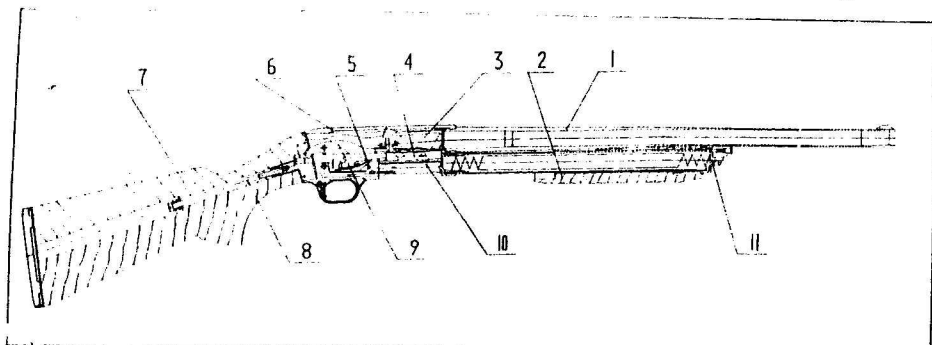

Fig. 1

PUMP SHOTGUN

2. Operating principles:

The forend can slide back and forth along the magazine, connected with the bolt frame through the medium of left, right pulling lever. After firing, pull the forend backwards with your hand. In this condition, the bolt frame, bolt body etc. act with the forend. The procedures of opening breech, extraction, ejection have been effected and the hammer will remain in firing position. Move the forend forwards to thrust the shell into the chamber and lock the breech. Now the gun gets ready to be fired.

The safety is located at the back end of the trigger. Push the safety button to the left side so that red mark appears. Now the gun is in firing position. Push the safety button to the right side and the red mark can be covered. The trigger is dead and all gun is in safe position.

II. Operations

1. Loading:

Push the safety button into the safe position to the right side. Pull the forend back to a certain place(not shorter than a shot). Now load a round into the chamber(Fig. 2). Move the forend forwards so as to lock the bolt, and then load the other 4 rounds into the magazine(Fig. 3)

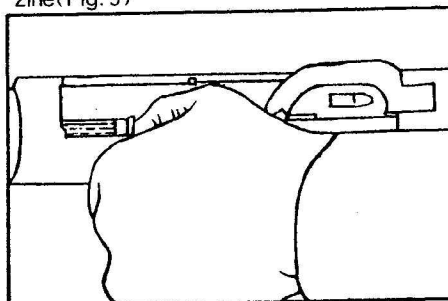

Fig. 2

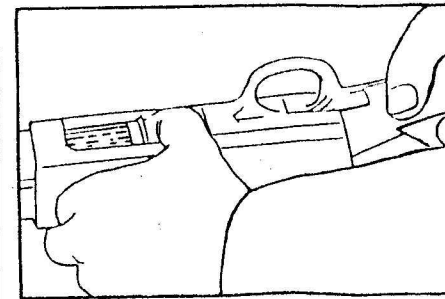

Fig. 3

2. Firing:

Push the safety into the firing position to the left side(red mark appears). Now, aim at your targets and pull the trigger(Fig. 4)

3. Ejection:

After firing, pull the forend to the back end, the fired shell case will eject under the action of the follower.

4. Thrusting the shot into the chamber:

Push the forend forwards so that the shot will be raised up to a certain position by the follower. The shot will be thrust into the chamber by the bolt.

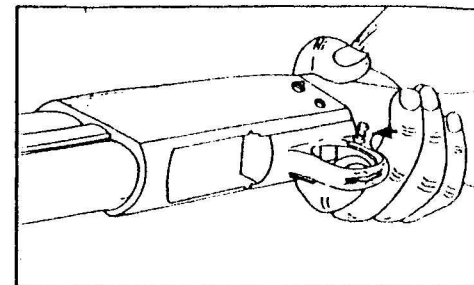

Fig. 4

PUMP SHOTGUN

V. Cautions

1. In no use, you must remove the shots from the chamber and the magazine. The concrete procedures; Push the safety button into the safe position. Press the sliding lock forward, and then pull the forend backwards. The shells in the chamber and the magazine will eject out in turns.
2. Push the safety into the safe position, when no target is found, even if you are sure there is no shot in the gun.
3. Only when you are in intention of firing, the finger of yours can touch the trigger. In other cases, the finger should grasp the trigger guard or other parts instead of the trigger.
4. Before using the gun, check the chamber and the bore to see if it is clear of any obstructions. Don't use it until you clean out the dirt and wipe the grease.
5. Only use the same shots whose gauge and size should meet the need of the gun.
6. After firing, wipe out the powder residue from the bore, apply antirust oil inside. The bore and all metal parts must keep clean in order to prevent it from rusting.
7. Basic oil is not allowed to permeate through the wooden parts. Otherwise, they would be cracked and brittle.
8. The gun should be applied with winter oil at the temperature below -5°C .
9. According to the condition of use, periodic cleaning of metal parts is required with oil and store it with a coat of oil. To avoid damaging or losing the parts, frequent reassembly is unnecessary.
10. During the storage, the hammer should be released in fired position.
11. The shotgun will place in a dry and ventilated position. The gun and ammunition must be stored separately.

VI. The Exploded View of the Shotgun

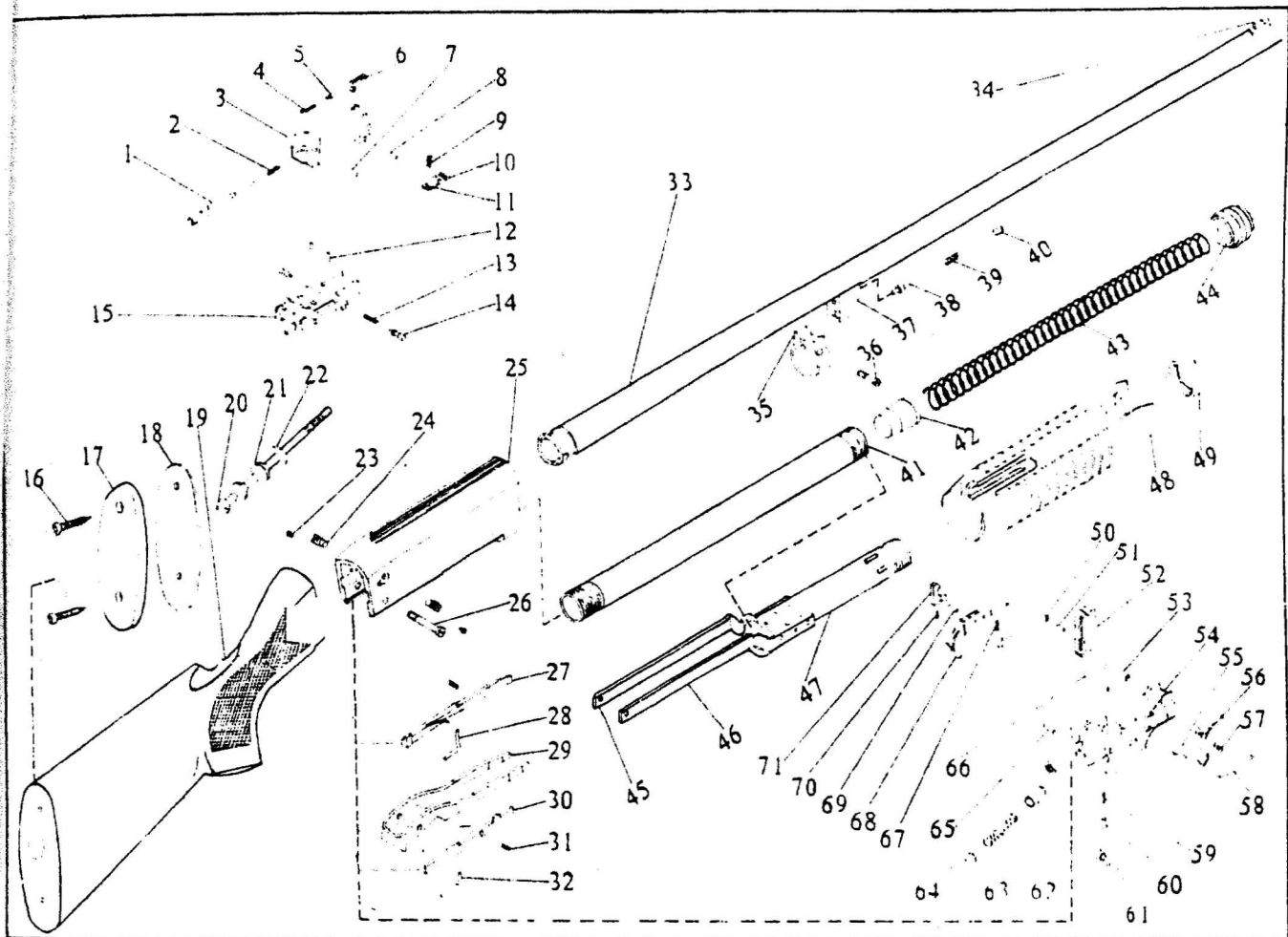

Fig. 7